

NATIONAL HISTORIC PARKS AND SITES BRANCH

MANUSCRIPT REPORT NUMBER 112

1968 ARCHAEOLOGICAL EXCAVATIONS
AT FORT BEAUSEJOUR

by
William Dendy
1969

1970 ARCHAEOLOGICAL EXCAVATIONS
AT FORT BEAUSEJOUR

by
William Dendy
1973

PARKS CANADA

DEPARTMENT OF INDIAN AND NORTHERN AFFAIRS

1968 Archaeological Excavations
at Fort Beausejour
by William Dendy

1970 Archaeological Excavations
at Fort Beausejour
by William Dendy

1968 Archaeological Excavations at Fort Beausejour
by
William Dendy

The Manuscript Report Series is printed in a limited number of copies and is intended for internal use by the Department of Indian Affairs and Northern Development. Copies of each issue are distributed to various public repositories in Canada, for use by interested individuals.

Many of these reports will be published in Canadian Historic Sites: Occasional Papers in Archaeology and History, and may be altered during the publishing process by editing or by further research.

1968 Archaeological Excavations
at Fort Beausejour

by

William Dendy

viii Preface

1	Sub-floor Excavations in Operation 2E16
1	Introduction
2	Excavation units
3	Description of Features
3	Floors and their Substructures
3	Room 1
5	Room 2
6	Room 3
8	Room 4
10	Room 5
11	Room 6
13	The Sub-floor Structure 2E16Y1
15	Fireplaces
16	Walls
16	The Drainage System
17	Doorways
17	Evidence of the Superstructure
18	Artifacts
19	Stratigraphy
19	Interpretation and Conclusions
25	Sub-floor Excavations in Operation 2E17
25	Introduction
26	Features
26	Walls and Fireplaces
28	Floors

30	Artifacts
31	Stratigraphy
31	Interpretation and Conclusions
37	Operation 2E12
37	Introduction
38	Description of Features
39	Walls
43	The Vault
45	The Fireplace
47	The Window in the East Wall of the Casemate
49	The East Entrance of the Casemate
52	The Brick Drain
55	The Floor in the Casemate
55	Bricks
56	Artifacts
58	Stratigraphy
59	Interpretation and Conclusions
63	The Continuation of Excavation in Operation 2E20
65	Excavations in Suboperation 2E23B
65	Features
66	Stratigraphy
66	Interpretation and Conclusions
68	References Cited

Tables

69	1	Length of the smaller bricks found in Operation 2E12.
70	2	Width of the smaller bricks found in Operation 2E12.
71	3	Thickness of the smaller bricks found in Operation 2E12.
72	4	Length of the larger bricks found in Operation 2E12.
73	5	Width of the larger bricks found in Operation 2E12.
74	6	Thickness of the larger bricks found in Operation 2E12.

- 75 7 Soil stratigraphy layers of the north face of 2E12B.
 76 8 Soil stratigraphy layers of the west face of 2E12B.
 77 9 Co-ordination of soil stratigraphy layers on the
 north and west faces of 2E12B.
 78 10 Lot-layer correlation of the soil stratigraphy
 layers on the north and west faces of 2E12B.

Illustrations

- 81 1 Floor Plan of Men's Barracks 2E16.
 82 2 Diagram of the sub-floor structure 2E16Y1.
 83 3 Diagram of the planking of 2E16Y1, in side view,
 showing the slope of the planking and the partition
 wall between Rooms 4 and 5.
 83 4 Diagram of the notching of the beams in 2E16Y1.
 84 5 Diagram of the drain found in Room 4, lot 2E16V4.
 85 6 Diagram of beam 8 of Room 2 of the 2E16 Barracks.
 86 7 Diagram of beam 8 of Room 5 of the 2E16 Barracks.
 87 8 Elevation view of a tentative reconstruction of the
 2E16 Barracks.
 88 9 The 2E17 Floor Plan.
 90 10 Plan of the basement of the earlier building on the
 site of the 2E17 Barracks.
 91 11 View of the west wall of the earlier structure.
 Camera facing west.
 91 12 Fireplace on the west wall of the barracks.
 Camera facing west.
 92 13 Barrel 2E17Q5-1 Camera facing east.
 92 14 Overall shot of barrel. Camera facing east.
 93 15 Reconstructed Floor plan of the 2E17 Barracks.
 94 16 Post excavation shot of 2E12F, showing the concrete
 lintel and the top of the masonry steps into the
 casemate. Camera facing north west.
 96 17 Site plan of 2E12.

- 99 18 Location and dimensions of the suboperations in the east half of 2E12, in relation to the structures.
- 100 19 North face elevation view - 2E12.
- 101 20 South face elevation view - 2E12.
- 102 21 East face elevation view - 2E12.
- 103 22 West face elevation view - 2E12.
- 104 23 2E12Q6: Post excavation shot showing the open space in lower right corner of excavation which is the inlet of drain No. 1, and the difference in construction between the upper and lower parts of the south wall of the casemate. Camera facing south.
- 104 24 2E12: General view of the east end of the British Casemate, showing the abutting below the window, the brick drain, the spring of the arch on the north and south walls. Camera facing east.
- 105 25 2E12: General view of the east end of the British Casemate showing the abutting below the window and of the extension to the main east wall of the casemate, and the bonding of the east wall to the south wall. Camera facing west.
- 105 26 2E12F5: Post-excavation shot showing wall north of the north wall of the casemate. Camera facing down and east.
- 106 27 2E12F21: Post-excavation shot showing the rubble found east of the casemate, camera facing south.
- 106 28 2E12: View of the east end of the casemate. Camera facing west.
- 107 29 2E12: View of the south half of the east end of the vault, showing rubble above arch. Camera facing west.
- 108 30 Elevation drawings of fireplace at east end of casemate, operation 2E12.
- 109 31 Horizontal and vertical views of the fireplace at east end of 2E12.

- 110 32 Diagram of the names and initials on the lintel of the fireplace at the east end of the casemate.
- 111 33 View of the back wall of the fireplace at the east end of the casemate, showing brick wall and rubble wall. Camera facing south.
- 111 34 View of the east fireplace in the casemate showing the top of firebox and metal braces. Camera facing up.
- 112 35 Post-excavation shot. Camera facing south.
- 112 36 Post-excavation shot. Camera facing north.
- 113 37 General view of the west end of the British Casemate, showing the brick drain and the floor structure. Camera facing west.
- 114 38 Sketch of the soil stratigraphy of the north and west faces of 2E12B.
- 117 39 2E20 plan showing location of suboperation 2E20R.
- 118 40 Post-excavation shot showing the east side of the west wall of 2E20J. Camera facing east.
- 118 41 Post-excavation shot showing the south side of the north wall of 2E20M. Camera facing south.

Preface

From June 3, 1968 to September 5, 1968, I took part in archaeological excavations at Fort Beausejour National Historic Park, Aulac New Brunswick, under the direction of Mr. Jervis D. Swannack, Jr., Senior Archaeologist and his assistant, Miss DiAnn Herst, of the Research Division, National Historic Sites Service, Department of Indian Affairs and Northern Development, Ottawa, Ontario.

My work on Operation 2E12, the British Casemate, between Prince Edward and Prince Henry Bastions, was done in conjunction with M. Gerard Gusset, a graduate of L'Université de Montréal, and under the direction of M. Pierre Nadon of the Research Division, National Historic Sites Service. Mr. Steve Epps and Mr. A.E. Wilson, both of the above department did the final plan of the structure and the elevation drawings of the interior walls, respectively. M. Georges Lupien of the same department did the mosaic photograph of the standing portion of the brick vault, and helped me with the mosaic photographs of the interior walls of the casemate, and other areas of the casemate.

The crew of labourers which worked with me on Operation 2E12 were: Jim Chapman, Larry Delany, Harry MacDonald, Dean Scobie, Derek Tower, Fred Tower, Mike Mesheau, Dan Perkins, David Rogerson, Doug Trenholm, Edgar Voutour, Eric Wheaton.

I directed the excavations of the east end of the structure and I am reporting on this part and on the floor structure beneath the standing portion of the casemate and the complete drainage system of the casemate. M. Gusset is reporting on his section of the structure and on the excava-

tions conducted by M. Nadon.

I also carried out sub-floor excavations in Operation 2E16, the Men's Barracks between Prince Henry and Prince Frederick Bastions, between July 11 and August 14, 1968. The crew of labourers which worked with me in this operation were: Albert Legere, Dan Scopie, Dean Scopie, Doug Trenholm, Eric Wheaton.

From August 21 to September 5, 1968 I conducted sub-floor excavations in Operation 2E17, the Officer's Barracks between Prince Edward and Duke of Cumberland Bastions. The crew of labourers which worked with me were: Bobby Burke, Ed Goodwin, Allan Tower. The photographs of the 1968 excavations in 2E17 were taken by myself and by Georges Lupien.

From August 20 to September 3, 1968, I continued the excavations begun in 1967 in Operation 2E20, Prince Frederick Bastion. The crew of labourers that worked with me were: Willis Goodwin, David Rogerson, Eric Wheaton. The photographs of the 1968 excavations in 2E20 were done by myself and by Georges Lupien.

From July 4 to July 9, 1968 I conducted excavations in an exploratory trench in the parade square south of Operation 2E19, which was designated as part of Operation 2E23, suboperation 2E23B.

Sub-floor Excavations in Operation 2E16

Introduction

The excavations conducted in Operation 2E16 were to ascertain the nature of any structures which might exist beneath the level of the wooden floor of the basement of the Men's Barracks, Operation 2E16, which had been excavated in 1966 (Coleman: 1966), "since three buildings were reported to have occupied the site between 1751 and 1852 (Nadon 1966: J:2; L:3; Korvemaker 1967: 46). In 1966 a small trench, 2E16R34, was cut beneath the level of the floor exposing a lower floor (Coleman 1966: 22, 36). During 1967, further sub-floor excavations were carried on in the north half of the barracks but no sub-floor structures were found. An extremely high water table on the site prevented further excavation (Korvemaker 1967: 46). However, a lower water table in 1968 facilitated this summer's work.

The sub-floor excavations in 2E16 involved the recording of those sections of the floor which remained in situ, their removal, excavation below floor level and the examination of features such as walls and fireplaces to see if they bore any relation to a lower structure. The features exposed and recorded in the course of these excavations are of two types: (1) the substructure of the upper floors, beams, levelling blocks and building debris; found in all rooms of the barracks; (2) the sub-floor structure designated 2E16Y1 consisting of four walls and a partially preserved floor, found beneath Rooms 4 and 5 of the barracks. Further excavations were made below these features to test for lower structures.

Since 2E16 had been covered by a shed after the 1966

season to protect the exposed structure, it was necessary to take all photographs using flash, both electronic and bulb. The low ceiling of the shed made it impossible to take elevations with a level; instead a string line was used from an established benchmark on one of the shed posts. However, all elevations were recorded in terms of height above sea level. The spacing of all beams was measured from the middle of the beam to the face of the wall or the middle of the beam.

Excavation Units

The excavation units employed were a continuation of the sub-operations established in the earlier excavations of 2E16. For the most part the structural divisions of the barracks determined lot boundaries. The building is divided into six rooms numbered 1 to 6, from North to South (Fig. 1). Rooms 1 and 3, and 4 and 6 open into Rooms 2 and 5 respectively, through doors in the west ends of the partition walls. The dimensions of Rooms 1, 3, 4, 6 are 12.5 ft. north-south and 17.5 ft. east-west; those of Rooms 2 and 5 are 6 ft. north-south and 17.5 ft. east-west.

Lots 2E16W1 through 2E16W4 were the clean-up of the barracks prior to recording. Part of 2E16W1 was finished in 1967 (Korvemaker 1967: 46).

Lots 2E16W5 through 2E16W10 were the recording and removal of those sections of the floor that remained in situ. Lots 2E16W5 and 2E16W7 were finished in 1967 (Korvemaker 1967: 46).

Suboperation 2E16V was the excavation and recording of any feature found below the level of the floor. Lots 2E16V1 through 2E16V6 are the excavations in Rooms 1 to 6 respectively, to an average depth of 0.77 ft. below floor level, or 120.38 ft. A.S.L. Lots 2E16V1 and 2E16V3 were begun in 1967 (Korvemaker 1967: 46). Lot 2E16V7 was an extension of

the excavation in Room 6 to an average depth of 1.19 ft. below floor level, or 119.63 ft. A.S.L. (Fig. 1).

Sub-operation 2E16Y, consisting of one lot, was assigned for the purposes of recording to the sub-floor structure exposed beneath Rooms 4 and 5 in lot 2E16V4 and 2E16V5. (See Section A.2 of this part of the report for a description of this structure. See Fig. 1 for the exact location of the structure.)

Sub-operation 2E16X, consisting of one lot, was a sub-floor excavation beneath 2E16Y1 (Fig. 2). Its dimensions were 1.82 ft. north-south by 5.4 ft. east-west, and its average depth was 0.88 ft. below the structure designated 2E16Y1, 1.62 ft. below the floor level of Room 4 and 119.35 ft. A.S.L.

Description of Features

Most aspects of the features found in 2E16, Men's Barracks, have been reported in the reports on the 1966 and 1967 excavations (Coleman 1966: 22-47; and Korvemaker 1967: 46-56). Therefore this report is primarily concerned with the wooden plank and sleeper beam floors exposed in 1966 in each of the rooms and their related substructures; and also with the sub-floor structure found beneath Rooms 4 and 5 and designated 2E16Y1. However, some aspects of other features such as doorways, fireplaces and drainage are discussed.

Floors and Their Substructures (Fig. 1)

Room 1. The floor planking exposed in this room was removed in 1967 (Korvemaker 1967: 46), but the beams and levelling blocks remained in situ. There are nine well preserved beams, running generally north-south in this room (Fig. 1). Beam 2, located in the doorway into Room 2, does not extend to the north wall of the room. Beam 3 also does not abut the north

wall of the room. Beam 3 also does not abut the north wall of the room as does beam 1; its span is completed by a shorter beam, 3A. The span of beam 1 and 3-3A averages 13.1 ft. Beam 4 abuts the front of the fireplace and the partition wall, with a span of 8.87 ft. Beams 5-8 abut the same partition wall and the south edge of the brick hearth and of the brick paving that runs along the front (south) edge of the oven base. Beams 1-3 do not extend into Room 2, through the doorway, but abut roughly beam 8 at Room 2 (Korvemaker 1967: 47). Beams 5-8 have an average span of 6.7 ft. The beams in this room were laid so that the horizontal width is less than the vertical thickness, although beam 2 was laid in the reverse fashion. The average horizontal width of the beams is 0.38 ft.; the average vertical thickness is 0.45 ft. The average spacing of beams 1 and 8 from the west and east walls respectively is 0.82 ft. The average interspacing of beams 1-8 is 2.44 ft., varying from a minimum of 1.28 ft. between the north ends of beams 6 and 7 and a maximum of 3.23 ft. between beams 1 and 3A.

Under the beams were found nine wood fragments, designated A-F and H (Fig. 1), which were probably used to level the beams before the planking was put in place. These levelling blocks run generally either parallel to the beam they support or at right angles to it. They were laid directly on the soil. Beams 1-3, 3A, 7 and 8 are not supported by any levelling blocks, but lie directly on the soil. Wood fragment G is not under a beam, but rather under a section of the brick hearth. The fragmentary nature of the pieces and their average thickness of 0.08 ft. indicate that these are probably utilized construction debris.

The average elevation of the upper surfaces of the beams is 121.38 ft. A.S.L., with no noticeable directional slump. The average elevation of the excavation floor in

this room is 120.6 ft. A.S.L. No indication of sub-floor structures was found in this room.

Room 2. The floor in this room, which was defined as including the doorways into Rooms 1 and 3, consisted of seventeen planks which were in a fair state of preservation at the beginning of the season (2E-1834 X, 2E-1835 X, Fig. 1). These planks were aligned east-west across beams running north-south. The planks seem to have been laid in two sections, one running from the west wall and beam 1 to beam 5, and another from beam 5 to the east wall. Each of the doorways was floored by two planks running east-west. The planking was secured by ten surviving nails, which are discussed as artifacts. (See "Artifacts" in this chapter.)

Planks 2-8 and 2-9 in this room were not removed because a roof-supporting post of the protective shelter was resting on them. They could, therefore, not be measured. This also prevented a examination of the flooring sub-structure in the doorway between Rooms 2 and 3.

The average thickness of these planks was 0.11 ft.; the average width was 0.68 ft., varying from a minimum of 0.32 ft. to a maximum of 1.12 ft. The average elevation of the upper surfaces of the beams was 121.5 ft. A.S.L.

The sub-floor structure of the plank floor in Room 2 consists of eight beams, (Fig. 1) beams 1-7 running north-south, and beam 8 running east-west spanning the doorway into Room 1. Beams 1 and 3-7 abut both the north and south walls of the room. The north end of beam 2 abuts beam 8 and may abut a similar beam running east-west across the doorway into Room 3, because of its association with the doorway is discussed in Section 6. The average span of beams 1-7 is 5.43 ft., increasing from a minimum of 5.1 ft. for beam 1 to maximum of 5.8 ft. Like those in Room 1, beams 1-7 were

laid so that the horizontal width is less than the vertical thickness, although beam 7 was laid in the reverse manner. The average horizontal width of the beams is 0.34 ft. and the average vertical thickness is 0.49 ft. The average spacing of beams 1 and 7 from the west and east walls respectively is 1.12 ft. and 0.67 ft. The average interspacing of beams 1-7 is 2.68 ft., varying from a minimum of 2.28 ft. between beams 6 and 7 to a maximum of 3.05 ft. between beams 1 and 2.

The beams were found associated with twelve wood fragments (Fig. 1): nine, designated A, B, C, F, G, H, L and M were used as levelling blocks, placed in the same manner as those in Room 1. Fragments D, J and K were probably construction debris. All the beams were supported by levelling blocks, and beams 6 and 7 were further supported by one stone placed under each beam. A stone was placed under fragment F to achieve the desired level. The average thickness of 0.13 ft. of these pieces and their fragmentary nature indicates that they were utilized construction debris; the plank-like nature of fragments D, J, K supports this hypothesis.

Pinkish beach-type sand was found sandwiched between fragments J and K. This sand seems similar to that used in mortar at the site. This is added evidence for the practice of dumping building debris under the floor.

The average elevation of the upper surfaces of the beams in this floor is 121.36 ft. A.S.L., with no appreciable directional slump. The average elevation of the excavation floor in this room is 120.55 ft. A.S.L. No indication of sub-floor structures was found in this room.

Room 3. The floor planking exposed in this room was removed in 1967 (Korvemaker 1967: 46). There are eight beams and thirteen wood fragments in the substructure of this floor

(Fig. 1). Beam 1 abuts the north and south walls of the room. Beams 3 also extends from the doorway and abuts the south wall of the room. On an analogy with beams 1-3 of Room 1, beams 1-3 and wood fragment A of this room do not extend into Room 2, but abut a beam in the doorway similar to beam 8 of Room 2 (Korvemaker 1967: 50). The average span of beams 1 and 3 is 11.42 ft. Beams 4-8 abut the north wall of the room; of these, 4 does not span the room; 5 abuts the north wall (front) of the fireplace; 6 abuts the north edge (front) of the brick hearth. Beams 7 and 8 do not reach the south wall; the span, however, is completed by fragments J and K respectively. The average total span of beam 7-fragment J and beam 8-fragment K is 11.12 ft. Like those in Rooms 1 and 2, these beams are laid so that the horizontal width is less than the vertical thickness. The average horizontal width is 0.38 ft. and the average vertical thickness is 0.49 ft. The average spacing of beams 1 and 8 from the west and east walls respectively is 0.82 ft. and 1.43 ft. The average interspacing of beams 1-8 is 2.49 ft., varying from a minimum of 1.05 ft., between beams 1 and 2, to a maximum of 3.65 ft., between beams 7 and 8.

Thirteen wood fragments were found in this room, designated A-M (Fig. 1). A and B seem to be construction debris; through H, M and N are levelling blocks; fragments J and K are on edge running parallel and adjacent to the beams. The levelling blocks are arranged as they were in Rooms 1 and 2, but fragments M and F support fragments D and G respectively rather than a beam. Beam 1 has no levelling blocks or stones under it; beam 3 is only supported by a stone and beams 7 and 8 are supported by two stones each in addition to wood fragments. The average thickness of the wood fragments is 0.19 ft.

Between beams 7 and 8 there is a deposit of medium

sized stones, which included one brick. This seems to be building debris discarded beneath the floor boards.

The average elevation of the upper surfaces of the beams is 121.12 ft. A.S.L., with no appreciable directional slump. The average elevation of the excavation floor in this room is 120.26 ft. A.S.L. No indication of sub-floor structures was found in this room.

Room 4. The surviving flooring in this room consisted of six planks, located in the nooks on both sides of the fireplace, three on each side (Fig. 1). The good state of preservation of these planks and most of the exposed sleeper beams indicates that the missing planks were removed because a roof-supporting post of the protective shed was resting on it. These planks could not, therefore, be measured and the substructure of the floor beneath them could not be examined.

One of the nails which secured the planking was found during excavation. (See "Artifacts" in this chapter.)

The average width of the planks was 0.87 ft., varying from a minimum of 0.81 ft. to a maximum of 0.96 ft. The planks on the west side of the fireplace, average elevation 121.09 ft. A.S.L., were slightly lower than those on the east side of the fireplace, average elevation 121.27 ft. A.S.L.

The substructure of this floor consists of six beams running north-south; there are no wood fragments (Fig.1). Beams 1 and 2 abut the north wall of the room, and extend into the doorway into Room 5, but do not abut beam 8 of Room 5. The average span of these beams is 12.4 ft. Beam 3 abuts the south (front) wall of the fireplace, and also the south wall of the room. The north ends of beams 4-6 are covered by plank 4-4, but it is likely that they abut the north wall of the room. Beam 4 does not span the room. Beams 5 and 6 abut the south wall of the room and their average span is 12 ft. Un-

like the beams in Rooms 1-3, the beams in this room are laid so that the horizontal width is greater than the vertical thickness. Only beam 1 was laid in the reverse fashion. The average horizontal width of the beams is 0.42 ft.; the average vertical thickness is 0.32 ft. There is a great variation in the thickness of the beams, from a minimum of 0.17 ft. at the south end of beam 3, to a maximum of 0.47 ft. the middle of beam 1. Beam 4 was so deteriorated that only rough measurements could be taken by comparison with beam 5. The average spacing of beams 1 and 6 from the west and east walls respectively is 1.22 ft. and 0.7 ft. The average interspacing of beams 1-6 is 3.89 ft. varying from a minimum of 1.15 ft. between beams 5 and 6, to a maximum of 6.9 ft. between beams 3 and 5.

There are no wooden levelling blocks under the beams in Room 4, but beam 1 is supported by a stone which is probably building debris. Beam 2 lies on top of the west wall of the sub-floor structure designated 2E16Y1, uncovered in this room and in Room 5. Beams 3 and 5 run across the north wall of this structure and are supported by the stones of this wall. Beams 4 and 6 rest on soil.

The average elevation of the upper surfaces of the beams in this room is 121.1 ft. A.S.L., with no noticeable directional slump. The average elevation of the excavation floor is 120.38 ft. A.S.L.

During the excavation of this room the inlet of drain no. 3 was found immediately below floor level. This drain leads through the west wall of the barracks from the space between beam 1 and the west wall (Fig. 1). This feature is discussed in "The Drainage System". (See also Zeller 1968.)

A sub-floor structure, designated 2E16Y1 was partially exposed in this room, and partially in Room 5. This struc-

ture is discussed in "The Sub-floor Structure".

Room 5. The surviving floor in this room, which was defined as including the doorways into Rooms 4 and 6, consisted of twenty-one planks or fragments of planks, aligned east-west (Fig. 1). These were in a fair state of preservation at the beginning of the season. Planks 5-4 and 5-7 had deteriorated quite badly. Planks 5-11 and 5-16; 5-12, 5-13 and 5-17; 5-14, 5-15 and 5-18 seem originally to have been three planks, a north-south split having occurred where the planks were laid across beam 6. The floor was laid in two sections: one section extending from the west wall and beam 1 to beam 5; the other extending from beam 5 to beam 7 and the east wall. Each of the doorways was floored by two planks; this is the same arrangement as in Room 2. The planking was secured by ten nails discussed in "Artifacts" part of this chapter of the report. Planks 5-9 and 5-10 were not removed because a roof-supporting post of the protective structure was resting on them; therefore they were not measured and the substructure of the floor beneath them was not examined.

The average width of the planks was 0.86 ft. and their average thickness was 0.12 ft. The average elevation of the upper surfaces of the planks was 121.15 ft. A.S.L., with no appreciable directional slump.

The substructure of the floor in Room 5 consists of eight beams and ten wood fragments (Fig. 1). Beams 1-7 run north-south, spanning the room; beam 8 runs east-west across the doorway into Room 4. Beams 1, 3-7 abut both the north and south walls of the room. The north end of beam 2 abuts beam 8 and probably abuts a similar beam in the doorway into Room 5. The average span of beams 1-7 is 5.8 ft. Like the beams in Rooms 1-3, the beams in this room are laid so that the horizontal width of the beam is less than the vertical

thickness, except for beam 7 which was laid in the reverse manner. The average horizontal width of the beams is 0.36 ft. and the average vertical thickness is 0.44 ft. The average spacing of beams 1 and 7 from the west and east walls respectively is 1.12 ft. and 0.72 ft. The interspacing of beams 1-7 averages 2.68 ft., varying from a minimum of 2.1 ft. between beams 6 and 7, to a maximum of 3.16 ft. between beams 3 and 4.

Associated with the beams of this floor are ten wood fragments (Fig. 1). A-H and K are levelling blocks placed in the same manner as those in Rooms 1-3. Fragment J is a piece of construction debris. The average thickness of the wood fragments is 0.09 ft. Beams 2 and 6 lie on top of, and are partially supported by, the west and east walls of the sub-floor structure, 2E16Y1. Beams 3-5 cross the south wall of this structure at right angles and are supported by the stones of it.

The average elevations of the upper surfaces of the beams is 120.96 ft. A.S.L., with no appreciable directional slump. The average elevation of the excavation floor is 120.31 ft. A.S.L. The southern portion of the sub-floor structure, found beneath Room 4, was exposed in this room.

Room 6. The surviving floor in this room consisted of 15 planks and six wood fragments (Fig. 1). Planks 6-1 to 6-10 and 6-12, 6-13 are definitely planking; 6-14 seems to be a piece of baseboarding (Coleman 1966: 34, Fig. 5). However 6-15 is not shown on Fig. 1, and several wood fragments present at the beginning of the 1968 season were not parts of the floor in situ. They are probably fragments surviving from other sections of the building which settled here during the flooding of the site. The lack of certain sections of the flooring is best explained as the result of looting, as

in Room 4 (Coleman 1966: 33).

Plank 6-1 was not removed because a roof-supporting post of the protective shed was resting on it. Planks 6-7 to 6-10 could not be removed because of wall slump. These planks were not measured and the substructure of the floor beneath them could not be examined.

Eight nails which secured the floor were found during the excavations.

The average width of the planks of this floor was 0.8 ft. and the average thickness was 0.12 ft. The average elevation of the surface of the planks was 121.14 ft. A.S.L., with no noticeable directional slump.

The substructure of the floor in Room 6 consists of eight beams and six wood fragments (Fig. 1). Beam 4 seems to be a remnant of the superstructure of the barracks and is discussed in the Chapter "Evidence of Superstructure". The south ends of beams 1A and 2A are covered by planks 6-7 to 6-10, so that it cannot be determined whether they abut the south wall of the room and what their span is. Beams 1 and 1B extend from the doorway into Room 5, but their north ends are covered by planks 6-1, of this room, and 5-9 and 5-10 of Room 5. However, on the analogy of beams 1-3 in Room 1, it is probable that beams 1 and 1B abut a beam similar to beam 8 in Room 5. Beam 2 does not span the room, but the span is completed by beam 2A which lies parallel and adjacent to it. Beam 3 abuts the north (front) wall of the fireplace. Beams 2, 3 and 5, 6 abut the north wall of the room. Beams 5 and 6 abut the south wall of the room and their average span is 12.64 ft. Like the beams in Rooms 1-3 and 5, the beams in Room 6 were laid so that the horizontal width is less than the vertical thickness, except for beams 1A and 1B, which are laid in the opposite manner. The average horizontal width of the beams is 0.37 ft., the average vertical thick-

ness is 0.44 ft. The average spacing of beams 1 and 6 from the west and east walls respectively is 0.75 ft. and 1.12 ft. The average interspacing of beams 1-3 and 5, 6 is 2.8 ft., varying from a minimum of 0.9 ft. between beams 1 and 1B, to a maximum of 7 ft. between beams 3 and 5.

There are six wood fragments in this room. Fragments A-D and F are levelling blocks, placed like those in the other rooms. Fragment E is probably a piece of construction debris. The average thickness of these fragments is 0.08 ft. There are not levelling blocks under beams 1 and 5, but beam 5 is supported by a stone.

All the beams, except for beams 1 and the exposed portions of beams 1A and 1B, have a layer of light grey, mortar-like soil (10YR 7/1) beneath them, varying in thickness from negligible to 0.15 ft. This soil is not found under the beams in the other rooms.

The average elevations of the upper surfaces of the beams in this room is 120.9 ft. A.S.L., with no appreciable directional slump. The average elevation of the excavation in 2E16V6 is 120 ft. A.S.L. Lot 2E16V7 was dug between beams 3 and 4 (Fig. 1) to an average elevation of 119.63 Ft. A.S.L.

Many medium sized stones were found in this lot which may be building debris or remains of the torn-down walls of another earlier structure.

No indications of the foundations of a sub-floor structure were found in this room.

The Sub-floor Structure 2E16Y1

The sub-floor excavations in the 2E16 Men's Barracks uncovered a structure beneath Rooms 4 and 5 (Fig. 1, 2). This structure consists of four stone walls one course high enclosing a partially preserved floor of planks and sleeper beams. It is almost a square in shape and its walls are approximately

parallel to the walls of the barracks. The partition wall between Rooms 4 and 5 cuts across the east and west walls of the structure at right angles.

The exterior horizontal dimensions of the walls are: north wall - 12 ft; east wall - 12.5 ft.; west wall - 12.35 ft.; south wall - 12.1 ft. The interior horizontal dimensions of the walls are: north wall - 9.6 ft.; east wall - 10.6 ft.; west wall - 10.65 ft.; south wall - 9.8 ft.

The walls consist of one course of stones that are roughly shaped and positioned so that their interior faces present a straight line. The average elevation of the upper surfaces of the walls is 120.56 ft. A.S.L., with no noticeable directional slump.

The floor of the structure consists of twenty planks or fragments of planks, running north-south. Planks Y1-5 to Y1-16, located south of the partition wall slope deeply to the North (Fig. 3). Those on the north side of the partition are not sloped. It appears that part of the flooring was looted, and when the Men's Barracks was built, the partition wall was either placed directly on the floor or a foundation trench was smashed through the floor. Either action would explain the slope. The second hypothesis seems preferable, because the weight of the wall would have buckled the floor north of the partition equally with that south of the partition.

As the planking was not removed, it was not possible to get complete measurements for individual planks and beams. The average width of the planks measured is 0.81 ft.; their average thickness is 0.08 ft. The average elevation of the planks north of the partition is 120.24 ft. A.S.L. The planks to the south of the partition slope downwards to the North at an angle of between 15 degrees and 20 degrees.

There are six beams partially exposed. Beams 1, 3, 4

and 5 run east-west and beams 2 and 6 run north-south. Beam 2 is notched into beams 1 and 4 (Fig. 4); Beam 6 is almost covered by plank Y1-1. No beams are exposed south of the partition wall. The average width of the exposed beams is 0.38 ft. Only the thicknesses of beams 4 and 5 could be measured, and their average thickness is 0.3 ft. The average elevation of the upper surfaces of the beams is 120.21 ft. A.S.L.

A test trench 2E16X1 was dug below the floor level of the structure between beams 4 and 5 and planks Y1-4 and Y1-18. (Fig. 2). The average elevation of the excavation floor of 2E16X1 is 119.17 ft. A.S.L. No indication of a lower sub-floor structure was found in this lot.

Fireplaces

The construction of the fireplaces in the 2E16 Men's Barracks has been previously reported (Coleman 1966: 40-46), but during the excavations of 1968, I re-examined the fireplace on the south wall of Room 6 to see if it bore any relation to an earlier or sub-floor structure. The two courses of cut stone on each side of the firebox, which stand 1.36 ft. high on the east side of the firebox, are not supported on another course of cut stone below the surface of the hearth. These stones and the bricks of the hearth rest on a four-sided rubble platform. The front (north) edge of the platform is 8.5 ft. from the interior face of the south wall of the room and 6.9 ft. from the interior face of the firebox. This platform rests on the sterile soil reached in the sub-floor excavations. This examination and the sub-floor excavations in Room 6 indicate that this fireplace bears no relation to an earlier or sub-floor structure. A similar examination of the fireplace in Room 4 showed that it was not connected with the structure designated 2E16Y1. It is likely that the same conclusion

applies to the other fireplaces in the barracks.

Walls

The walls of the 2E16 Men's Barracks have already been examined (Coleman 1966: 28-31). However, on the post-excavation site plan made in 1966 (Fig. 1), the fabric of the partition wall between Rooms 4 and 5 was not shown as being exposed. The fabric of this wall was exposed during the sub-floor excavations in Room 5 (Fig. 1).

Drainage System

Part of the drainage system of the 2E16 Men's Barracks has been previously examined (Coleman 1966: 25-28). When the floor planking west of the fireplace in Room 4 was removed, a section of covered wooden drain ending in a metal grate was exposed (Fig. 1, 5). This drain was designated as part of Drain No. 3. It was located immediately beneath the floor planking, between the west wall of the room and beam 1, and was only partially covered by the fill under the floor. On either side of the drain was located a medium sized stone; no stones were found on top of the drain. The drain entered the room at an angle and is exposed 0.8 ft. on the north side and 0.68 ft. on the south side. It is 1.1 ft. wide. The metal grate in front of the drain was 1.05 ft. long and perforated by several rows of holes. The elevation of the upper surface of the drain cover is 120.87 ft. A.S.L. and the elevation of the upper edge of the grate was 121.04 ft. A.S.L. The drain was clearly meant to drain Room 4 and perhaps by extension Rooms 5 and 6. The grate was a cover to prevent the clogging of the drain.

A more complete account of this drain and its relation to the remainder of the fort drainage system will be found in the 1968 report by A. Zeller.

Doorways

The doorways in the 2E16 Men's Barracks have been previously discussed (Coleman 1966: 31-33; Trudel 1966). This section of the report will examine the further evidence for their structure which was revealed during the sub-floor excavations (Figs. 1, 6, 7). The doorways between Rooms 2 and 3, and 5 and 6 could not be examined because roof supporting posts rested on the floor planking in these areas.

Beam 8 of Room 2 runs east-west, spanning the doorway into Room 1. This beam is 4.62 ft. long, and averages 0.7 ft. wide and 0.32 ft. thick. At either end of the beam is a notch which runs through the beam; they average 0.36 ft. east-west and 0.33 ft. north-south. The surface elevation of this beam is 121.3 ft. A.S.L.

Beam 8 of Room 5 also runs east-west, spanning the doorway into Room 4. The beam is exposed for a length of 3.55 ft., being partially covered by the partition wall. It averages 0.61 ft. wide and 0.29 ft. thick. At either end of the beam is a notch which runs through the beam, averaging 0.35 ft. east-west and 0.23 north-south. The average elevation of the upper surface of this beam is 120.76 ft. A.S.L.

The notches of these beams would have held the door jambs (Coleman 1966: 31; Fig. 4).

Evidence of the Superstructure

A feature found in the sub-floor excavations of the 2E16 Men's Barracks is beam 4 of Room 6, the position of which may indicate either that it had fallen from the superstructure or shifted from its original position in the substructure of the floor.

The length of the beam, 6.56 ft., is such that it could have been laid east-west between beams 3 and 5, which have a separation of 7 ft. (Fig. 1). But spacings of a nearly com-

parable width occur in Rooms 3 and 5, and in none of the rooms was a main sleeper laid east-west.

On the other hand, beam 4 lies partially on the rubble platform that forms the fireplace base. Though the upper surfaces of the other beams have an average elevation of 120.91 ft. A.S.L. (maximum 120.03 ft. A.S.L.), the elevation of beam 4 varies from 120.92 ft. A.S.L. to 121.6 ft. A.S.L. Clearly any planking laid on the other beams could not have extended over this beam. The condition of this beam is worse than most of the beams found in the floor substructures (2E-1316X). Its south end appears to have been broken. Although the north end of the beam lies just under plank 6-1, the evidence seems to indicate that beam 4 collapsed and fell from some section of the superstructure of the barracks.

Artifacts

The usual sorts of artifacts: pipestems, glass, pottery, etc., were found throughout the sub-floor excavations of the 2E16 Men's Barracks (Coleman 1966: 46-47; Korvemaker 1967: 50). But an especially high concentration was found below Room 3 (Korvemaker 1967: 50) and in Room 4. Parts of a leather boot, or boots, came from this room. Presumably the concentration of artifacts was partially due to the accumulation of garbage over the subfloor structure 2E16Y1, when the upper floor was built. Generally the artifacts seem to be English of the late 18th century or the early 19th century.

The most common artifacts were the badly corroded nails used to secure the floor planking to the beams (Coleman 1966: 34). These nails seem to be forged iron, with flattened heads. They were generally 0.02 ft. by 0.02 ft. square in cross-section. The nails averaged 0.26 ft. long, with a maximum of 0.4 ft. In each room long nails were used alongside short nails.

Stratigraphy

The extremely wet conditions during which the sub-floor excavations were made, made it impossible to excavate according to soil stratigraphy. In these excavations the artificial levels of floors were more significant, but it is possible to speak of the soils associated with the various levels of the floor structure.

Above the floors, which remained in situ at the beginning of excavation, was a layer of loam 7.5YR 4/2 dark brown. This layer was caused by the slump and deposition of two winters and one summer of flooding.

Below the floors was a sandy clay or clay layer, which varied from 5YR 4/2 dark, reddish-grey to 5YR 4/3 reddish-brown. Some of this soil was probably placed as fill beneath the floor structures, but most would have been gradually deposited during occupation and after the building was abandoned. Immediately above the floor of the structure designated 2E16Y1 was a layer of greasy loam, 7.5YR 2/0 black. This soil is an occupation layer.

Excavation beneath the sub-floor structure designated 2E16Y1 disclosed a greasy loam, 7.5YR 2/0 black, which lies just below the planking and is a continuation of the occupation layer above this floor.

Continued excavation in this area and in Room 6 uncovered a layer of clay, 5YR 4/2 reddish-grey, which is the sterile sub-soil of the site of the 2E16 Men's Barracks.

Interpretation and Conclusions

It is possible from the historical sources to ascertain the presence of three buildings on the site of the 2E16 Men's Barracks. The first was built by the French as an Officers' Barracks and is shown, on "Plan de Fort Beausejour, Franquet, 1751" (Nadon 1966: Appendix 1) and "Plan et Profil du Fort de Beausejour par M. de Jonquiere, 1752" (Nadon 1966: Appen-

dix 6), as extending the length of the curtain wall between what were to be Prince Henry and Prince Frederick Bastions. This building was a one story, wooden structure, 26 ft. by 69 ft., with four chimneys (Nadon 1966: K: 2). This building probably had no basement (Nadon 1968: 63). In 1754 a new Officers' Barracks was built between what were to be Prince William and Duke of Cumberland Bastions, and the old Officers' Barracks became a Men's Barracks. When the British besieged the fort, after June 4, 1755, this building, like the others in the fort except for the new Officers' Barracks and the guardhouse, was demolished to make cannon manoeuvres more feasible (Nadon 1966: B: 7), demonstrating the lack of a basement and the general fragility of the building.

On "A Plan of Fort Cumberland, Breuse, October 18, 1755" (Nadon 1966: Appendix 6), the barracks is not shown, and may therefore be presumed to have actually been demolished. But on the plan "Fort Cumberland, including blockhouse, c. 1757" (Nadon 1966: Appendix 6), a building is shown extending the length of the curtain wall between Prince Henry and Prince Frederick Bastions. On "Plan of Fort Cumberland, HM 15414 (Nadon 1966: Appendix 6), drawn between 1757 and 1761 (Nadon 1966: E: 1), a similar building on this site is designated as a storehouse. In 1761 a storehouse within the fort, not in the spur, is mentioned with the barracks as being in good condition. Following the abandonment of the fort in 1768 (Nadon 1968: 75), the barracks were found to be so deteriorated that when the fort was reoccupied in 1776, all the barracks were repaired or rebuilt (Nadon 1968: 75). The 1778 plan of the fort by Spry again shows a provision store occupying the 2E16 site. In 1785 repairs were made to an Officers' Barracks and a Men's Barracks, which have been assumed to be respectively the building between Prince Edward and Duke of Cumberland Bastions, and that between Duke of Cumberland and Prince William Bastions. At this time the first mention of

stone foundations in the records occurs (Nadon 1966: L: 2). The building on this site was described in 1803 as having eight rooms, a cellar, a kitchen and three chimneys; and further in 1823 as a two storey building 66 ft. by 24 ft., used as an officers' barracks (Nadon 1966: L: 14). In 1845 only three buildings are described as standing, and the barracks mentioned in 1803 is not among them (Nadon 1966: M:3); by 1901 all the wooden structures in the fort had collapsed (Nadon 1966: D: 1).

From the remains found in the excavation of 2E16 in 1966-1968, it is possible to describe the building that was the last to stand on this site. It clearly had three chimneys and six rooms in the basement, one of which was a kitchen. At the time of the original excavations in 1966, Rooms 2 and 5 were designated as storerooms (Coleman 1966: 30). This was likely partially the case, but I believe that the rooms served principally as halls containing the stairways to the ground floor. This arrangement would have provided equal access to the larger, more usable rooms on either side of Rooms 2 and 5 and would have avoided the obvious disadvantages of having a stairway in one of the larger rooms. A similar arrangement probably existed in the French Officers' Barracks built in 1754 (Nadon 1966: k: 7; Appendix 5). As storerooms only Rooms 2 and 5 would have been inconveniently narrow, but as stairhalls they are a good width and would have provided storage space under the stairs. Parts of the stair structures, recognizable as such, would have disappeared almost completely or have been easily removed.

The plan of the two above-ground stores, which the building is described as having in 1823, would probably have closely duplicated the basement plan to allow the walls in the basement to support the weight of partition wall in the upper storey. Considering the rooms above 2 and 5 as stairhalls and thus not really rooms, there would have been eight rooms in the build-

ing. The basement rooms would have been considered as a cellar and a kitchen.

The building as a whole (Fig. 8) was probably constructed in wood as a "double building", like the Men's Barracks between Prince William and Duke of Cumberland Bastions and the 1754 French Officers' quarters, if these two buildings are the same (Nadon 1966: 1: 10; Appendix 5). The solid partition between Rooms 3 and 4 probably extended upward to divide the building into two separate halves. Each half would have had a separate entrance, leading logically into the central hall. The presence of a door would provide a reason for there being no windows into Rooms 2 and 5; the space would have been blocked by the doorway stoop. Providing the design was consistent with the symmetrical techniques of design common in the 18th and early 19th centuries, there would have been, in the ground storey, a window into each of the rooms above Rooms 1, 3, 4, 6 on a line with the basement windows identified during excavation (Coleman 1966: 36-39). On the second floor, there would have been one window into the four rooms on a line with the basement windows, plus one into each of the upper halls above the doorways. An attic storey probably completed the building but nothing can be said for sure about its fenestration, if it had any, or about its interior arrangement. The three chimneys of the building would have risen at least slightly above the roof.

It is not possible to say nearly as much about the building which was built prior to the one described above, to which the sub-floor structure designated 2E16Y1 belonged. 2E16Y1 consists of a partially complete floor and one course of the field stone surrounding wall. It may have formed a partial basement for a larger structure, since no building of this size is recorded as having existed on the site. It was no doubt a basement storeroom, without any provision for a fireplace or probably for ventilation. The presence of a

floor may mean that the goods were of a perishable type. The dismantling of the basement seems to have been intentional as there is no evidence of fire on the floor planking and little in the way of debris associated with the structure. The same may apply to the building that stood above, and if so it might have been dismantled to allow the construction of the later Men's Barracks.

From the description of the buildings that occupied the site along the curtain wall between Prince Henry and Prince Frederick Bastions, it is obvious that the structure excavated in 1966-1968 is not the French barracks, for this would have lacked the basement that has survived and would have been generally fairly flimsy in construction. However, its dimensions, 26 ft. by 69 ft., are very similar to those given for the latest building on the site, which is 24 ft. by 69 ft. and similar to those of the excavated structure, 21 ft. by 75 ft.

It is equally obvious that the barracks described in 1803 and 1824, as being two stories high, with three chimneys, eight rooms, a cellar and a kitchen fits the structure excavated. The problem remaining, however, is to relate this structure to the storehouse, shown after 1757, and to assign a date to it. The crucial time periods are 1776 and 1785; during both years reconstruction was carried out at the fort. The rebuilding of 1785 seems to have involved only the barracks between Duke of Cumberland and Prince Edward Bastions and between Duke of Cumberland and Prince William Bastions. This leaves no place for the building or rebuilding of a barracks between Prince Henry and Prince Frederick Bastions. The fact that stone foundations are not mentioned earlier than 1785 at Fort Beausejour (Nadon 1966: M: 2) need not preclude their use previously. The technique was common enough and could be easily overlooked. The sub-floor struc-

ture, 2E16Y1, was part of a stone foundation and must antedate 1785 as this is the last date that it could be demolished to be replaced by the later structure. I believe that, when all the barracks were rebuilt or repaired around 1776, that the storehouse marked on plan HM 15414 was torn down and a completely new barracks with a full basement was built. That the new barracks was described, on Spry's plan of 1778 (Nadon 1966: Appendix 6), and may be due to a misconception or ignorance of the building's use on the part of the draftsman.

Speaking just of the results of the 1968 excavations, it is possible to say that they uncovered the remains of a basement storeroom, belonging to a larger storehouse built after the first British occupation of the fort. This storehouse would have had at least partial stone foundations. The storehouse was built on the site of one storey, cellarless barracks demolished by the French during the seige of 1755. The remains of the partial basement of the storehouse are the only structure underlying the later Men's Barracks.

On a wider scale, the excavations of 1966-1967 have exposed a barracks built by the British in the period immediately following the second occupation of the fort in 1776. To build it, the British demolished the superstructure and the cellar of an earlier storehouse.

Sub-floor Excavations in Operation 2E17

Introduction

During the 1966-1967 excavations of the 2E17 Officers' Barracks, three stone walls, forming the north, east and south foundation walls of an earlier structure, were located within the boundaries of the barracks (Fig. 11; MacDonald 1967: 2-29). The purpose of the 1968 excavations was to ascertain the relationship of these walls to each other and to the later structure; to locate the west wall of the earlier building; and to excavate below the level of this building and test for the presence of earlier structures.

It was necessary to remove the partition walls of the later structure that were not part of the earlier building: those between Rooms 2 and 3, and 3 and 4. All of the floor structure in Rooms 2, 3, 4 and part of that in Room 5, which had been found in situ in 1966-1967 (MacDonald 1967: 2-29), were removed to allow excavation below floor level (Fig. 9). A section of the west wall of the later building was dismantled to expose the west wall of the earlier structure. Further sub-floor testing was carried out in the area of Room 2 (Fig. 9).

The earlier structure on the site was found to consist of three rooms (Figs. 9, 10), and the excavation units largely correspond to these divisions. The south room includes Room 1 of the later building; the central room, Rooms 2, 3 and 4; and the north room, Room 5.

2E17Q1 was the clearing of the previous winter's collapse and deposition in the barracks, and the removal of the floor planking. Lot 2E17Q2 was the clearing of Rooms 2, 3

and 4 of the later structure to expose the central room of the earlier structure. Excavation was carried to an average depth of 0.56 ft. below the level of the floor or 116.04 ft. A.S.L. Lots 2E17Q3 and 2E17Q4 were the clearing of Rooms 5 and 1 respectively to reveal the north and south rooms of the earlier structure; no real excavation was done in the lots. Lots 2E17Q5 and 2E17Q6 were sub-floor excavations below the level of the earlier structure. (See Fig. 9 for the location and dimensions of these lots.) The average elevation of the excavation floor of 2E17Q5 was 116 ft. A.S.L. 2E17Q6 was made larger than 2E17Q5 to include the clearing of a section of the west wall of the earlier structure. The lot was partially excavated to a maximum depth of 112.9 ft. A.S.L. to allow for removal of barrel 2E17Q5-1.

Features

The earlier building on the site of the Officers' Barracks was oriented north-south, as was the barracks. Its overall dimensions are 65 ft. north-south by 19 ft. east-west, as compared with 72 ft. north-south by 22 ft. east-west for the barracks (Fig. 9, 10). The building consisted of three rooms, each containing a fireplace. The northern room is 15.4 ft. north-south long and 14.1 ft. east-west wide, with a fireplace on the north wall (MacDonald 1967: 20). There is a doorway in the east end of the partition separating it from the next room. The central room is 26 ft. north-south long and 14.2 ft. east-west wide, with a fireplace in the centre of the west wall. The southern room is 15 ft. north-south long and 14.4 ft. east-west wide, with the remains of a fireplace in the middle of the South wall.

Walls and Fireplaces

The north, east and south walls of the earlier structure

have been described in the report on the 1966-1967 excavations (MacDonald 1967: 3-6, 11-14, 17, 18, 21-28). However, until 1968, no section of the west wall of this building had been exposed. It was possible, prior to excavation, to see a course of squared stone in the west wall of the later building. This was in contrast to the rubble wall above it (Fig. 11). During excavation, 6.2 ft. north-south of this course, the west wall of the earlier structure, was exposed. It averages 2.21 ft. wide. It rests on firm clay, as does the east wall (MacDonald 1967: 17) at an elevation of 115.31 ft. A.S.L. at the north end of the exposed section, and at 115.5 ft. A.S.L. at the south end. The wall stands two courses high and is constructed of shaped blocks of what appears to be grey sandstone.

The partition walls between the central room and the north and south rooms have been described previously (MacDonald 1967: 10-12, 26), but it is possible to say that the protruding section of the south wall of the south room is simply the partially preserved rear wall of the chimney base and firebox. The north fireplace was designed in the same way. The hearth of the north fireplace was examined and the top two layers of brick previously noted were removed, and the lowest layer uncovered. The top layer was of bricks, averaging 0.72 ft. by 0.34 ft. by 0.17 ft., laid on edge. Below this was a light grey mortar layer, 10 YR 7/2. The second layer of the hearth consisted of brick fragments; there were no whole bricks. The bricks in this layer were laid flat. The lowest layer, which was not removed, was of whole bricks laid flat. Beneath the hearth was soil which does not seem to contain any artifacts, reddish-brown, sandy clay 5YR 4/3. This layered hearth indicates at least two repairs to the fireplace.

The fireplace in the west wall was only tentatively

described as a fireplace in the report of the 1966-1967 excavations (Macdonald 1967: 17, 19). The partitions between Rooms 2 and 3, and 3 and 4 of the later building (Fig. 9) concealed the side walls of the firebox. When these partitions were dismantled the shape of the fireplace became apparent (Fig. 12). The construction of this fireplace is markedly dissimilar to that of the west wall of the later building, but quite similar to that of the west wall of the earlier structure (Fig. 12). The fireplace is also centered on the wall of the central room of the earlier building, while being next to unusable in Room 3 of the later structure. It might have been completely incorporated into the later structure, when it was built. Alternately, it is possible that the back of the firebox was rebuilt, the side walls being retained. The back appears to be more of rubble construction than the sides (Figs. 11, 12).

Floors

The flooring, which was uncovered in the excavations of 1966-1967 and removed in 1968, has been discussed in the 1967 report on the Officers' Barracks (MacDonald 1967: 7-29). When the flooring was removed in Rooms 2, 3 and 4 the beams were also removed. Beams were removed in Rooms 1 or 5. The beams were saved to facilitate further investigation.

Three beams were found in the floor of Room 2, which were numbered from south to north, beam 1-Room 2, 2-2, 3-2. Beam 1-2 was 14.6 ft. long, 0.7 ft. wide (horizontal and 0.6 ft. thick vertical). It was squared at both ends and held five nails, 0.35 ft., 1.3 ft.; 13.2 ft. and 13.75 ft. from the west end of the beam, in situ position. Beam 2-2 was 14.55 ft. long. 0.64 ft. wide. 0.52 ft. thick and held no nails. The west end of the beam was notched; the notch was 0.34 ft. east-west and 0.3 ft. north-south and located 0.85

ft. from the west end of the beam. The notch does not extend through the beam, but contains a dowel 0.09 ft. in diameter. The west end of the beam is roughly pointed; the north side of the point is 0.35 ft. long; the south, 0.6 ft. long; the axis, 0.51 ft. long. This notch and point indicate that the beam would have been previously used in another position. Beam 3-2 was 14.65 ft. long, 0.45 ft. wide and 0.35 ft. thick. This beam was squared at both ends and held two nails, 2.43 ft. and 3.06 ft. from the west end of the beam.

Three beams were found in the floor of Room 3, which were numbered 1-3, 2-3, 3-3. Beam 1-3 was 11.5 ft. long, 0.58 ft. wide and 0.5 ft. thick. It held four nails 1.1 ft., 6.9 ft., 7.5 ft. and 8.9 ft. (this last nail is questionable) from the west end of the beam. Beam 2-3 was 11.4 ft. long and 0.58 ft. wide and 0.5 ft. thick. The beam was squared at both ends and held ten nails 0.25 ft., 2.4 ft., 3.6 ft., 4.4 ft., 4.95 ft., 5.2 ft., 6.45 ft., 7.8 ft., 8.75 ft. and 10.35 ft. (this nail is questionable) from the west end of the beam. Beam 3-3 was 14.75 ft. long, 0.61 ft. wide and 0.39 ft. thick and contained no nails. There was a tenon at the west end of this beam, 0.25 ft. long and 0.13 ft. thick, whose upper surface was 0.16 ft. below the upper surface of the beam, and whose lower surface was 0.18 ft. above the lower surface of the beam. The presence of this tenon indicates that the beam was used in another position before being incorporated into the floor. This beam was found under the partition wall between Rooms 2 and 3 (Fig. 9). The elevation of its upper surface was 116.36 ft. A.S.L.

Four beams were found in the floor of Room 4, numbered 1-4, 2-4, 3-4 and 4-4. Beam 1-4 was 13.4 ft. long, 0.58 ft. wide, 0.48 ft. thick and contained eight nails 1.55 ft., 2.13 ft., 2.85 ft., 8.15 ft., 8.65 ft., 9.25 ft., 11.85 ft., 12.4 ft., from the west end of the beam. This beam was found un-

der the partition wall between Rooms 3 and 4 (Fig. 9). Beam 2-4 was 14.65 ft. long, 0.75 ft. wide and 0.48 ft. thick. It was split at the east end and held eight nails 1.3 ft., 2.85 ft., 5.1 ft., 6.7 ft., 7.35 ft., 8.7 ft., 9.35 ft., 10.35 ft. from the west end. Beam 3-4 was 14.7 ft. long, 0.72 ft. wide and 0.4 ft. thick. This beam may have been sawn or hewn and is possibly robbed from some other location. There is a tenon 0.3 ft. long. It held five nail 0.25 ft., 0.95 ft., 1.8 ft., 2.95 ft., 11 ft. from the west end of the beam. Beam 4-4 was 14.7 ft. long, 0.45 ft. wide and 0.4 ft. thick. There was no notching at either end. There were six nails in the beam 0.35 ft., 0.85 ft., 1.25 ft., 2.3 ft., 3.25 ft., 4.55 ft. from the west end.

Artifacts

Not many artifacts were found in the sub-floor excavations in the 2E17 Officers' Barracks, and what was found seems to be British.

During the excavations in lot 2E17Q5, a whole barrel was found buried in the ground below the floor levels of both the earlier and the later structures. This was given artifact number 2E17Q5-1. The barrel was without a top and was filled with black organic-like fill, 7.5 YR 2/0. The top of the fill of the barrel contained several pieces of a sandstone-like stone (Fig. 13). The elevation of the top of the fill was 116.3 ft. A.S.L.; the elevation of the top of the barrel staves was 116 ft. A.S.L. No artifacts were found in the barrel or around it. The elevation of the base of the interior was 112.9 ft. A.S.L.

All the staves of the barrel were preserved and some of the hoops were in position (Fig. 14). The bottom of the barrel was preserved.

When the barrel was lifted it fell apart, but the

pieces were saved and examined under laboratory conditions. The barrel stood 37 inches high. The bottom of the barrel was only held together and in place by pressure from the hoops and by the fitting into the croze of the staves. There were 24 staves, each with a croze of 1/8 of an inch. The barrel is unique among those found at the fort, in that it was very roughly made, and the end fragments showed no sign of dowel marking as did the others found.

Stratigraphy

Because these excavations in 2E17 were sub-floor excavations, the work was not done according to soil stratigraphy, but according to the levels of the buildings on the site, which were more significant in this case.

However it is possible to discuss the soil types found during the excavations. In all lots the soil varied from loamy clay to sandy clay, 7.5YR 4/3, brown, to 7.5YR 4/2, dark brown. This type of soil is common at Fort Beausejour and is close to the soil, 5YR 4/3 reddish-brown, that is described as being the lowest layer in the 1967 excavations (MacDonald 1967: 39). In and around the barrel an organic type of soil, 7.5YR 2/0 black, was found. This would be due to the decay of whatever the barrel held when it was abandoned, probably vegetables of some type.

Interpretations and Conclusions

The first building on the site of the 2E17 Officers' Barracks between Prince Edward and Duke of Cumberland Bastions was a storehouse shown on "Plan de Fort Beausejour, Franquet, 1751" (Nadon 1966: Appendix 1). The same building is also shown on "Plan et Profil du Fort de Beausejour par M. de Jonquiere, 1752" (Nadon 1966: Appendix 6) and on "Plan du Fort de la Pte de Beausejour, 1752" (Nadon 1966: Appendix 3), but the latter

plan shows the northern half of the building as unbuilt. It is not known whether the north half of the building was built (Nadon 1966: k: 6). It is likely that this building had no basement (Nadon 1968: 63). By 1754, the building was in such a ruinous state that the stores were kept outside the fort. The building was finally demolished during the seige of June 1755 (Nadon 1966: K: 6).

If this wooden storehouse was completed as planned, its dimensions were 64 ft. by 21 ft. It is not known whether it had any chimneys or not. At the south end there was a drain leading to the fosse via what was to be Duke of Cumberland Bastion (Nadon 1966: K: 6).

The British built an Officers' Barracks on the site of the French storehouse in 1755-1756, which in 1766, was described as a "single house" (Nadon 1966: L: 5), presumably in contrast with the barracks, on the site between Prince William and Duke of Cumberland Bastions, described by the same engineer as a "double building" (Nadon 1966: L: 10). In 1785, it is described as having twelve rooms, a cellar, and dimensions of 66 ft. by 18 ft. Repairs were made at this time to at least twenty windows. Repairs were also made during the War of 1812 (Nadon 1966: L: 5). In 1823, it is described as a privates' quarters with eight rooms. The building was standing in 1853 (Nadon 1966: L: 5). By 1901 all the wooden structures in the fort had collapsed (Nadon 1966: D: 1).

Originally the barracks seem to have been only one storey and later it seems to have been expanded to two stories, either in 1776 or during the War of 1812 (Nadon 1966: L: 5).

It is not possible to get as complete an idea of the design of the later structure that stood on this site as was possible for the 2E16 Men's Barracks. The cellar contained five rooms but it is not certain whether these would have been included in the twelve rooms noted in 1785 or the eight

rooms noted in 1823. It seems probable that for maximum convenience, the stairway from the ground floor was located in Room 3 (Fig. 9). There was only one fireplace in the basement, in Room 3, and it may not have been usable after the construction of the partition walls on either side of it. The large stone features, which occupy much of the area of Rooms 1 and 5, were probably the bases for chimney structures or oven bases. From the south end of the structure, the remains of a passage and drain lead to Duke of Cumberland Bastion (MacDonald 1967: 29-34).

Some elements of the arrangement of the upper floors can be deduced from the basement structures (Fig. 9, 15). There was probably a central room, corresponding to Room 3, and a set of two rooms on either side, above Rooms 1 and 2, and 4 and 5. The chimneys, supported on the bases in the basement structure, would be contained in the partition walls between the rooms of each set. The structure of the fireplaces and the chimneys need not have been as space-consuming as the bases in the basement, for these bases would have supported the hearths as well. The arrangement of the second floor was likely much the same as the ground floor. There was probably an attic storey, on the analogy with the other buildings in the fort (Nadon 1966: Appendix 5). The chimneys of the building would have risen at least slightly above the roof line.

There was likely a basement entrance at the north end of the building, but the location of other entrances of the building, the stairways, and the windows cannot be determined exactly from the historical or structural evidence. But I think that the main entrance was into the room above Room 3, with a stairway running up and down from this room. The majority of the windows were probably along the front of the building, for practical reasons of defence.

If Room 3 and the rooms above it were actually halls, and if the arrangement of the basement rooms was repeated on the upper two floors, there would have been twelve rooms in the building, counting those in the basement, and eight, not counting those in the basement.

Little can be said about the earlier structure, beyond the fact that it consists of three rooms, each with a fireplace. The outer walls were well built. That only a single course of unmortared stones, not closely positioned, is preserved for the partition walls seems to indicate that the surviving course was the base for a wall of somewhat lighter construction, probably wooden, or was removed later. The number and arrangement of the upper stories cannot be determined exactly, but the absence of interior supporting partitions and the less massive nature of the walls, as compared with the later building, may indicate that this building had only one aboveground storey. At some time during the evolution of this building a barrel was sunk beneath the floor for storage, but it was later abandoned.

It is obvious that neither of the structures excavated in 2E17 is the remains of the French storehouse. This building would have been quite flimsy and would have lacked the basement structures that have survived.

One other building is mentioned as having occupied the site, the British Officers' Barracks, but this building was first of one storey and then of two. I believe that the change from one storey to two indicates not the enlargement of the one storey building, but the complete building of a new two storey building.

The outer walls of the earlier structure seem to be too light to support the weight of a two storey building, and this is definitely true for the partitions. The exterior walls of the later building and its inner walls are strong

enough to carry the weight. In addition these walls are much too massively built to be part of a building that was originally planned as one storey. The number of rooms given for the barracks in 1785 and in 1823 correspond to a likely reconstruction of the later building, rather than to the earlier structure. That the dimensions given for the building in 1784, 66 ft. by 18 ft. (Nadon 1966: L: 5), relate more closely to the earlier structure than to the later, is a discrepancy that I am unwilling to strike off as a mistake in measurement.

There are three periods when the rebuilding of the Officers' Barracks could have occurred: in 1776, during the general rebuilding and repairing of the fort's barracks; in 1785, when repairs to this building are specifically mentioned; or during the War of 1812, when repairs were again done. Since the earlier structure seems to be of one storey, not containing twelve rooms, it could not have been standing on this site in 1785. The repairs that took place in 1785 are specifically minor in nature and did not include anything like the major project of building a new barracks. Thus the building must have been done before 1785, during the period following the re-occupation of the fort in 1776. The eight or nine years after this until 1785, allow sufficient time for the deterioration remedied in 1785.

From the historical and structural data, it appears that, after the 1755 seige the British constructed an officers' barracks on the site of an earlier storehouse demolished by the French during the seige. The dimensions of this and the later building on the site corresponded closely with those of the French building, assuming this was built as planned. The drain that was included in the French building was elaborated and incorporated into the structure of both later buildings on the site. This barracks was one storey high and had three chimneys.

When the fort was re-occupied in 1776, among the general repairs and rebuilding of the barracks, the officers' barracks was dismantled, down to the level of the cellar floor. The new barracks was larger, with a cellar of five rooms, some of the partitions of which were laid on the old floor. There were two and possibly three operative chimneys, the third being part of the earlier barracks. This barracks was two storeys high and probably had eight above ground rooms, and four in the basement, not counting the halls. There was probably an attic storey. Repairs were made in 1785 and again during the War of 1812. In 1823 the building was used as a privates' barracks. In 1853 it was still standing, but by 1901, it and all other wooden buildings at the fort had collapsed.

Operation 2E12

Introduction

During the summer of 1968, a stone casemate built in the curtain wall between Prince Henry and Prince Edward Bastions of Fort Beausejour was excavated. This excavation was designated Operation 2E12.

Historical records of the fort indicate that during the French occupation of the fort the main entrance was through this curtain and that there was a wooden bombproof casemate on either side of the gate. This arrangement was demolished by the British after the fort was captured and a stone casemate with a brick vault was built (Nadon 1966: I: i). Above the casemate a cannon battery, Loudoun's Battery was built (Nadon 1966: I: 5).

The excavation of the building was shared by M. Gérard Gusset, M. Pierre Nadon and myself. Generally M. Gusset will report on the west end of the structure and I will report on the east half. However, this report will also cover most of the interior wall structures, the interior drainage system, and that section of the casemate covered by the intact portion of the casemate vault.

Some excavation and stabilization was done on this casemate in 1925 (Nadon 1966: I: 1). A masonry retaining wall was built at each end of the standing portion of the vault which was capped by a concrete lintel. Access to the interior was by a set of masonry steps at the east end of the area covered by the standing portion of the vault (Nadon 1966: I: 2; Figs. 15, 16). It was necessary to remove the lintels, retaining walls and steps during the 1968 excavation.

Temporary scaffolding was used to guard against any collapse of the vault during the removal of these structures. There were no detrimental effects to the vault.

A small amount of preliminary excavation was done in Operation 2E12 by D. Herst in 1967.

The section of the excavations which I supervised was done in five suboperations: 2E12B, 2E12F, 2E12K, 2E12M and 2E12Q. These suboperations were divided into lots. Suboperations 2E12B, 2E12F and 2E12M were excavation within the main walls of the casemate. Lot 2E12B2 was excavated by Herst in 1967; lot 2E12B7 was the clearing of the fireplace in the east section of the south wall of the casemate. Suboperation 2E12M involved the removal of the steps and retaining wall and lintel at this end of the casemate; lot 2E12M4 was the clearing of a section of the east end of the standing portion of the casemate vault, 12.5 ft. north-south by 3 ft. east-west. Suboperation 2E12K was the excavation of a masonry structure attached to the exterior of the casemate below the opening in the east wall. Suboperation 2E12Q was the excavation and clearing of the floors throughout the casemate and of the brick drain which ran east-west the length of the casemate (Figs. 17, 20).

Description of Features

The main part of the casemate consists of four stone walls that were originally roofed by a brick barrel vault, the central third of which is still standing (Fig. 17). This section of the vault is covered by a layer of earth that is four feet thick at the thickest point. The exterior dimensions of the casemate are 81 ft. east-west by 20 ft. north-south; the interior dimensions are 74 ft. east-west by 10.6 ft. north-south. The walls are constructed of roughly smoothed coursed grey sandstone. The south wall of the case-

mate was named the North Stone Wall during the excavation of the barracks 2E19 south of the casemate of which it formed the north wall. The 28 ft. long section of the standing vault begins 21.5 ft. from the exterior of the east wall and ends 30.5 ft. from the exterior of the west wall.

Walls

The interior walls of the casemate are constructed of roughly-shaped coursed, grey sandstone, covered with a rough cast of natural coloured plaster, which is flaking on most parts of the surface. The shape of the blocks can be seen through the plaster (Figs. 19, 20, 21, 22). The north and south walls slope slightly outwards so that the casemate varies in width at the east end, from 10.35 ft. at the base of the walls to 10.5 ft. at the top of the wall; and under the east end of the vault, from 10.4 ft. at the base of the wall to 10.8 ft at the top of the wall.

The elevation of the tops of the north and south walls at the spring of the arch is 128.54 ft. A.S.L. Due to slight inaccuracies of excavation, the exposed height of the north wall is 6.42 ft., and that of the south wall, 6.56 ft. The average elevation of the floor of excavation is 122.06 ft. A.S.L. Excavation was continued to an average depth of 119.7 ft. A.S.L. in lot 2E1206 (Figs. 17, 23), which showed that the lower structure of the wall was more roughly built and lacks the coating of rough cast. The lowest visible course of the south wall, at the east end of the casemate protrudes slightly over part of its length. This is probably due to poor positioning of the stones, as it only occurs here. But it may indicate the height of the footer wall of the casemate.

The north wall of the casemate, at the east end of the casemate averages 3 ft. wide; the south wall averages 5.55

ft. wide.

The north wall of the casemate is widened by a lower step-like wall 2.1 ft. wide running east-west, north of, and adjacent to, the north wall of the casemate (Fig. 26). This wall is constructed of unshaped stones and a few brick fragments. The elevation of its upper surface varies from 128.86 ft. A.S.L. at the east end to 129.12 ft. A.S.L. at the west end of the exposed section. From my excavations it was not possible to tell whether the step was bonded to the north wall of the casemate or to the extension to the east casemate wall. The step seems to have been built to help support the outward stress of the vault of the north wall of the casemate. This step is part of the structure found at the west end of the casemate and is discussed in more detail by M. Gusset in his report.

Several letters are chipped into the rough cast of the north wall in the east end of the casemate. One name may be read: T. McFadden, and there is a set of initials: A. McK, with a date below it which could be 1822 or 1877. If it is 1822, the inscription would date from the final occupation period of the fort. Either date would provide a terminus post quem for the collapse of the vault.

The north and south walls covered by the standing portion of the vault are covered by initials, names and a few dates. It is probable that most of these date from the period after the site was finally abandoned.

There are some letters on the north wall at the west end of the casemate that will be described by M. Gusset in his report.

At the top of the north and south walls, where the vault has collapsed, the spring of the arch is preserved. It is completely preserved along the north wall, with an elevation of 129.13 ft. A.S.L. next to the standing vault,

and 130.13 ft. A.S.L. at the east end of the casemate. Along the south wall only one course is preserved in most places. The spring has an elevation of 129.98 ft. A.S.L. next to the standing portion of the vault and 129.24 ft. A.S.L. at the east end of the casemate. The preserved north section provides the best example of the construction. The interior face of the spring slopes at an angle of about 45 degrees; the exterior slopes much more steeply. The top of the spring is flat, varying from five to ten inches wide. The interior face is 2.85 ft. wide at the east end of the casemate and 2.65 ft. wide next to the standing portion of the vault. On the south wall the width of the surviving portions of the spring is 1.8 ft. at the east end of the casemate and 2.5 ft. next to the standing vault. On the north wall the interior face of the spring is quite smooth and covered with a crumbly yellowish mortar. The stones of the exterior face are only roughly shaped, but are also covered with mortar. On the south wall the mortar is missing from all but those sections which are closest to the standing portion of the vault. On the south wall the spring does not completely cap the wall as it does on the north wall (Fig. 25). The remaining part of the wall may have risen vertically several more courses.

The east wall of the casemate (Fig. 21, 24) is built like the north and south walls, of roughly shaped coursed grey sandstone blocks, and covered with a much deteriorated layer of rough cast. This wall was built in two sections (Fig. 17); the north section, which was built later than the southern section, is designated the Extension of the East Casemate Wall. This section is discussed separately from the south section.

In the centre of the east wall there is a window (Fig. 23), which is discussed separately. North of the window, the

wall is preserved to a maximum elevation of 130.01 ft. A.S.L. and south of the window to a maximum elevation of 129.13 ft. A.S.L. Thus the exposed height of the wall is 7.61 ft. north of the window and 7.24 ft. south of the window.

The interior corners of the east, north and south walls are bonded.

The exterior of the east wall is built in the same manner as the interior (Fig. 25). It is 18.3 ft. long north-south, not counting the length of the extension. The east wall is bonded to the north wall of 2E19 and fitted to the three-sided structure designated 2E12K.

The inner face of the east wall seems originally to have abutted the complete vault.

The extension to the east wall of the casemate runs north-south on a line with the east wall of the casemate (Fig. 17). This wall is exposed for a length of 9.5 ft. and varies from 2.5 ft. wide at its north end to 3.5 ft. wide at its south end. The wall is preserved to a maximum of 10.33 ft. high. On the east face of this wall the upper 8 ft. of the wall are built in the same manner as the exterior of the east wall of the casemate. However, parts of the upper courses were leaning dangerously to the east and had to be removed. The lower portion of the wall is of rubble construction. This difference in construction seems to indicate that only the upper part of the wall was meant to be seen. The west face of the wall is of rubble construction, and could not be completely excavated for fear of collapse. This seems to indicate that the west face was also not meant to be seen. The lower courses of this wall are abutted to the east casemate wall, but above an elevation of 130.04 ft. A.S.L. the two walls are bonded (Fig. 25). This indicates that the extension was built after the east wall of the casemate.

The extension to the east casemate wall was built after

the main part of the casemate, probably as a retaining wall to prevent any subsidence of the curtain wall supporting Loudoun's Battery into the gorge of Prince Henry Bastion. The ground level along the base of the wall would have been approximately 126 ft. A.S.L. which approximates the level at which the upper masonry structure of the wall begins.

East of the east wall of the casemate a line of rubble was found extending diagonally northeast from near the joint of the east wall and its extension (Fig. 17, 27, 29). This area of rubble was 11.2 ft. long and averaged 3.1 ft. wide. When first uncovered it appeared to be a wall, but was unmortared and only vaguely coursed. The south face was a jumble of blocks without pattern. It may be that the stones were rubble from the east wall. The elevation of the base of the pile averaged 126.74 ft. A.S.L. The stones were removed.

The Vault

The standing portion of the brick vault is 28 ft. long and begins 21.5 ft. from the exterior of the east wall, 18.5 ft. from the interior of the east wall; and 30.5 ft. from the exterior of the west wall, 27.5 ft. from the interior of the west wall. The vault rests on triangular springs on the top of the north and south walls (Fig. 28).

The span of the vault averages 10.8 ft. The arch is a 70 degree sector of a circle with a radius of approximately 9 ft. The arch is slightly flattened at its crest, either by design or due to the pressure from above. The distance from the interior crest of the arch to the floor of the brick drain is 8.5 ft; the distance from the junction of the interior face of the vault and the north wall to the floor of the drain is 8.5 ft.; the distance from the junction of the interior face of the vault and the south wall is 8.4 ft.

The elevation of the exterior crest of the vault is

133.14 ft. A.S.L. The vault is 2.64 ft. thick in the centre, 2.55 ft. thick at the south side and 2.52 ft. thick on the north side. The vault was constructed in three layers, held in place by mortar, 10YR 7/2 light grey, or white. The lowest layer, which forms the ceiling of the casemate, consists of bricks averaging 0.71 ft. by 0.34 ft. by 0.19 ft., laid with the brick lengths aligned east-west. There are both whole bricks and brick fragments in this layer. There are fifty-six bricks across the arc of the vault in this layer. The layer averages 0.39 ft. thick and there is a mortar layer of negligible thickness separating this layer from the one above. There is no sign that the ceiling of the casemate, the bottom of this layer, was coated with rough cast. This layer is bonded to the layer next above by twenty-three bricks, which are laid on end, with their lengths vertical. These bricks form part of the lowest layer and of the middle layer of the vault.

The middle layer of the vault consists of bricks the same size as those in the lowest layer. The bricks are laid in fifty-four vertical rows of three bricks. Two are laid with their lengths vertical, the third with its length east-west. Those twenty-three rows of which the lowest brick bonds the lowest layer to the middle layer, consist of three bricks laid with their lengths vertical. This layer averages 1.89 ft. thick. The mortar layer between the vertical rows is negligible in thickness; the layer between the bricks in the vertical rows varies from 0.04 ft. to 0.13 ft. thick. The mortar layer between the middle layer and the top layer of the vault varies from 0.03 ft. to 0.04 ft. thick.

The top layer of the vault consists of bricks, smaller than those in the other two layers, which average 0.63 ft. by 0.33 ft. by 0.16 ft. The bricks, all of which are fragmentary are laid with the length of the brick east-west. It is not

possible to count the number of bricks across the arc of the vault. This layer varies from 0.15 ft. to 0.2 ft. thick. There is no evidence of a moisture-proof layer within or above the vault.

Above the vault, where it rests on the south wall, it is possible to see that the south or exterior face of this wall was built higher than the spring of the arch, with part of its structure is preserved to a height of 131.81 ft. A.S.L. On the north side of the vault, where it rested on the north wall, there was rubble preserved resting on the top layer of the arch, to a height of 131.94 ft. A.S.L.

The Fireplace

There is a fireplace located in the south interior wall of the casemate (Fig. 20, 33, 34, 37, 38). The east side of the fireplace surround is 6.85 ft. from the southeast interior corner of the casemate; the west side of the surround is 12.3 ft. from the same corner. The surround is of cut stone, consisting of a lintel, five stones on the east side and two stones on the west side. The fireplace, surround and opening, averages 5.45 ft. wide; the firebox opening averages 4.54 ft. wide. The fireplace is 5.49 ft. high from the top of the surround to the floor of excavation; the firebox is 4.41 ft. high. The trapezoidal firebox is, as preserved, 2.19 ft. deep on the west side, 2.84 ft. deep in the centre, 1.89 ft. deep on the east side. The back of the firebox was faced with at least two thicknesses of brick, of which about thirty courses are wholly or partially preserved. Where the back wall has disappeared, it is possible to see the rubble core of the south wall of the casemate (Fig. 30). There is no hearth preserved for this fireplace and excavation was carried down to the rubble base of the fireplace and wall.

The elevation of the excavation floor at the northwest

corner of the firebox is 122.16 ft. A.S.L., and at the northeast corner, 122.3 ft. A.S.L. The elevation of the top of the lintel is 127.85 ft. A.S.L.

The lintel of the cut stone surround averages 5.34 ft. long. Its interior exposed length averages 3.71 ft. The lintel is cracked vertically in the middle and the west half is chipped along the bottom edge. The lintel averages 1.36 ft. wide. The depth of the lower edge of the lintel at the east and west ends is 0.6 ft., in the middle it is 0.25 ft. The lintel is deeper at the top than at the bottom, as the firebox narrows to join the flue. On the interior wall of the casemate, sections of three courses of brick are preserved (Fig. 20), which were probably placed there because they would put less pressure on the span of the lintel. The lintel has several initials and three names: F H Barnes, C Dixon and E C Martin carved into it (Fig. 32).

There are five stones on the east side of the surround and two stones on the west side. The lower three stones on the west side are missing and were not found during excavation. They must have been removed sometime before the vault completely collapsed.

The stones on the east side average 0.68 ft. wide, varying from 0.42 ft. high at the bottom to 1.04 ft. at the top, and from 0.79 ft. deep at the bottom to 2.02 ft. deep for the second stone from the bottom. The top three stones are smoked stained. The stones on the west side are both 0.66 ft. wide and vary from 0.82 ft. to 0.88 ft. high, and from 1.35 ft. to 1.55 ft. deep. Both these stones are smoke stained.

There is a notch on the interior side of the upper edge of each of the top stones in the surround. They are 0.27 ft. north-south, 0.35 ft. east-west and 0.07 ft. in height. These notches probably held a metal bar to brace the lintel

and hold utensils.

The opening of the flue can be seen in the top of the south wall of the casemate. A few bricks of the flue are still in place around this opening. The flue is 1.7 ft. from the interior face of the wall and 1.85 ft. from the exterior face of the south wall of the casemate. The flue averages 2.54 ft. east-west and 1.98 ft. north-south.

Two pieces of metal strapping were found in the upper part of the firebox (Figs. 31, 33, 37). Both pieces are 0.03 ft. thick. One piece is positioned with its wide side down and exposed for a length of 3.42 ft. It is 0.13 ft. wide. The other piece is positioned with its narrow edge down and is exposed for a length of 2.67 ft.; it is 0.15 ft. wide. These pieces of metal were probably used to brace the interior walls of the firebox. They are too light to support fireplace utensils and are in a difficult position for this.

The scaled elevations of the fireplace give the exact dimensions of the fireplace (Fig. 20, 30, 31).

There is another fireplace, similar to the one described above, located in the west end of the casemate, which will be described by M. Gusset in his report.

The Window in the East Wall of the Casemate

There is an opening, 4.5 ft. wide and 3.78 ft. high, in the east wall of the casemate that appears to have been a window. At the bottom of the opening is a brick ledge, average elevation 126.36 ft. A.S.L. (Fig. 17, 19). This ledge is built of three rows of bricks averaging 0.71 ft. by 0.34 ft. by 0.18 ft. The bricks in the eastern most row, along the exterior face of the wall, are laid with their lengths aligned east-west. On the exterior of the wall this row can be seen to be supported by four complete courses of stone similar to that of the east wall. The middle row consists mainly of bricks laid

on their sides with lengths aligned east-west. The northern two bricks of this row are laid flat with lengths aligned east-west. About one fifth of this and the second row are missing at the south end of the ledge. The ledge is supported on the interior side of the east wall by an area of rubble fill, and lower down, by four partially preserved courses of stone similar to that of the rest of the east wall. If the opening in the west wall was a window, as seems likely since the casemate would have needed light and ventilation, the ledge would have formed the window ledge.

At the top of the east wall of the casemate, on the north side of the window opening, is a roughly shaped trapezoidal stone, the south face of which is shaped like a spring of the arch. The average elevation of this stone is 129.98 ft. A.S.L. The stone is 1.9 ft. long east-west and 1.05 ft. wide. This stone could be the spring of an arch to span the opening in the east wall. But it would have to be a very flat arch if it were not to interfere with the ceiling of the vault, which would have an elevation of about 130.5 ft. A.S.L.

The average elevation of the top of the wall on the south side of the opening is 129.06 ft. A.S.L. The top stone has a notch in it (Fig. 17). This notch is 0.75 ft. east-west, 0.08 ft. north-south, and extends the thickness of the stone, 0.6 ft. The next stone down in the wall provides a ledge at the bottom of the notch. There are the remains of a similar notch on the north side of the opening. These notches may have held a beam to span the opening. A beam about 0.6 ft. by 0.75 ft. with an underside elevation of about 128.46 ft. A.S.L. would be more than adequate to support the wall above the opening. The support of ledges on the sides would be supplemented by the window jambs. It would be easier and more practical to span the opening with a beam than with an expensive and difficult flattened arch.

There is a further problem with the opening in the east wall of the casemate, because the four courses of stone that support the brick ledge on the exterior and interior of the wall are not bonded into the fabric of the wall (Fig. 24, 25, 27). On the exterior the stones below are butted on the north side of the opening and partially bonded on the south side of the opening. This indicates that the brick ledge and the courses below it were not built at the same time as the casemate. The opening would have gone from the floor to the level of the beam described for the window as there are no signs of a lower lintel. This would mean an opening 4.5 ft. wide, and, with a threshold at about 122.14 ft. A.S.L., about 6.32 ft. high. An opening this size must have been a doorway.

The door in the east wall is matched by the doorway in at the west end of the casement, which was never blocked during the life of the building. It is discussed by Gusset in his report.

The East Entrance to the Casemate

On the exterior side of the east wall of the casemate there is a low rectangular feature (Fig. 17, 36, 39), of which the north, east and south sides are formed by a low wall of coursed, shaped, grey sandstone. The west side is formed by the exterior east wall of the casemate. On the south side of the area enclosed by the wall are two ledges running east-west. The southernmost of these ledges averages 0.66 ft. lower, (or one course of stone), than the surrounding wall; the second ledge is adjacent to the first and 0.64 ft., or one course of stone lower than the first ledge. There is another ledge at the level of the second, running north-south, adjacent to the east wall of the feature.

This feature appears to be the entrance to the east end of the casemate. The two ledges are steps down made neces-

sary by the difference in level between the parade square and the floor of the casemate (Nadon 1966: I: 5). The purpose of the low ledge along the east wall of the feature is not apparent. The south side of the exterior wall has been designated Step One; the first ledge, Step Two; the second ledge, Step Three.

The exterior dimensions of the outer wall vary in width from 4.5 ft. on the north side to 5.5 ft. on the south side; the east side is 9.2 ft. long. The interior dimensions of the area vary in width from 3.8 ft. on the north side to 4 ft. on the south side. The area varies in length from 6 ft. on the east side to 6.5 ft. on the west side. The north side of the wall averages 1.3 ft. wide; the east 0.9 ft.; the south, Step One, 1.22 ft. wide.

The average elevation of the upper surface of the wall is 124.68 ft. A.S.L. The exterior of this wall is topped by one course of smoothed stone, below this the wall is rubble built. However, the interior is well-finished coursed stone down to the clay on which the wall is based (Fig. 36). This wall is not bonded to the exterior of the east wall of the casemate, but the stones are well-fitted to the surface of the wall. It is likely that the building of a small appendage like this feature would follow the construction of the main casemate walls, while still being contemporary with them.

The average elevation of the upper surface of Step One is 124.74 ft. A.S.L. The width is 4.43 ft.; the depth varies from 1.02 ft. at the east end to 1.4 ft. at the west end. The average elevation of the upper surface of Step Two is 124.08 ft. A.S.L. The width is 4.51 ft.; the depth varies from 0.65 ft. at the east end to 0.72 ft. at the west end. The average elevation of the upper surface of Step Three is 123.44 ft. A.S.L. The length is 4.55 ft.; the width varies from 0.98 ft. at the east end to 1.05 ft. in the middle.

The course of stone forming Step Three averages 0.98 ft. thick.

The elevation of the ledge level with Step Three, running north-south along the east wall of the feature is 123.34 ft. A.S.L. The length is 4.19 ft. The width varies from 0.44 ft. at the north end to 0.66 ft. at the south end. The course forming this ledge averages 0.79 ft. thick.

The area enclosed by Step Three, the ledge, the north wall of the feature and east wall of the casemate is 3.72 ft. on its north side, 4.3 ft. on its east side, 3.65 ft. on the south side and 4.45 ft. on the west side. Excavation was carried to an average overall depth of 120.74 ft. A.S.L. From the thicknesses of the courses forming Step Three and the ledge, the floor level in this area would originally have been about 122.56 ft. A.S.L. This is the level of the base of the four courses of stone which fill the lower part of the door into the casemate. However, no remains of paving or flooring were found; the floor level was probably just clay.

The area within this entrance was found to be filled with two types of soil. The level at which excavation began averaged 124.48 ft. A.S.L. From here to a depth averaging 124.03 ft. A.S.L., the soil was dark brown sandy clay, 7.5YR 4/2. Soil of this type continued downwards to a depth averaging 123.17 ft. A.S.L. in an area adjacent to the north wall, 3.95 ft. on the north side, 3.33 ft. on the east., 4.3 ft. on the south and 2.8 ft. on the west. South of this soil and underlying it to an average depth of 122.67 ft. A.S.L. was a layer of black greasy, loamy soil, 5YR 2/1, which contained many artifacts and oyster shell fragments. The lowest levels were filled with soil like that in the highest level.

The lowest level of the black soil is approximately that of the hypothesized floor level and from this level up there were many artifacts and oyster shells. This indicates that

the entrance was used as a rubbish dump, which could not have happened until the east door of the casemate was blocked, making the entrance useless. It is likely that the filling began shortly after the door was blocked and was finished soon after, since there was only one layer in the black fill. The area could then have been covered over with soil for reasons of sanitation.

The Brick Drain

There is an unmortared brick drain running east-west along the central axis of the casemate (Fig. 17, 24, 26, 36, 40). Some sections of the drain, particularly under the vault, are quite disturbed, probably due to frost heaving, vandalism, and the excavations of 1925 (Nadon 1966: I: 2). This drain, which is 73.6 ft. long and averages 1.62 ft. wide, outside wall to outside wall, includes a brick detritus-filled sump, approximately half-way along its length. The floor of the drain is made of a double row of bricks, laid with their lengths north-south. A section of the drain, beginning 14.7 ft. from the interior west wall, and extending to the west wall, had no brick floor. There was no evidence of a brick floor or that there was a wooden floor; this section of the drain must have been built without a floor. The sides of the drain are bricks laid with their lengths east-west, placed on the drain floor along its north and south edges. A section of the drain, beginning 16 ft. from the interior west wall and extending to the west wall, has sides two courses of brick high, instead of one course as in the rest of the drain. As the elevation of the tops of the sides of the drain remains fairly even, considering the slope of the drain, it may be that when the practice of flooring the drain with brick was discontinued, the sides were built one course higher to maintain an even level for the walls.

The drain was filled and covered with dark brown sandy clay, 7.5YR 4/2, which is like the soil fill generally found at Fort Beausejour.

From the east interior wall of the casemate to the sump the elevation of the floor and sides of the drain is fairly constant at 121.84 ft. A.S.L. and 122.20 ft. A.S.L. respectively, with a slight slope towards the east wall. From the sump to the west interior wall of the casemate the elevation of the floor of the drain drops fairly steadily from 121.95 ft. A.S.L. to 121.19 ft. A.S.L. the Elevation of the sides of the drain drops steadily from 122.4 ft. A.S.L. to 121.62 ft. A.S.L. The breaks in the slope are probable due to frost heaving of the floor during and after occupation, especially in the area still covered by the vault, which has remained open continually. The true slope of the drain east of the sump cannot be determined. However, it seems more likely that the drain flowed into the sump rather than out the east entrance, since there is no place for the water to go out the east entrance and no sign of a connecting drain. West of the sump, the drain slopes toward the west entrance, draining into the drainage system of the whole fort. Outside the west entrance there are the remains of a wooden drain, which may have connected with the brick drain. This wooden drain is discussed by Zeller in her 1968 report.

At the east end of the casemate the drain continues under the four courses of stone which block the east entrance (Fig. 24). This indicates that the drain was built before the east entrance was blocked and the steps outside abandoned. However, no remains of the drain were found on the exterior of the east wall.

At the west end of the casemate the drain is overlain by the beams of the casemate floor. Between these beams and the drain there is a layer of the same soil that filled the drain. The position of the beams indicates that the floor was laid after the drain, and the layer of soil may indicate that the floor was laid after the drain had become useless because of clogging. The bricks of the drain average 0.71 ft. by 0.34 ft. by 0.19 ft.

The centre of the sump on the brick drain is 32 ft. from the interior east wall of the casemate. When first uncovered it was an oval area, 5 ft. north-south by 4.6 ft. by 0.19 ft. The highest point on the detritus was 122.23 ft. A.S.L. When the detritus was removed the sump was found to be a cone-shaped hole, filled with sandy clay soil, 5YR 3/4 dark, reddish-brown, which was different in texture and colour from the surrounding soil. This pit had no actual man-made wall. The sump was excavated to a depth of 117.85 ft. A.S.L. Few artifacts were found in the pit. After excavation, a heavy rainstorm, which did not actually reach the sump from above, caused the bottom to fill with water. The direction of this flow would be reversed by a lower water table, allowing water draining into the sump from the casemate to flow away.

At the west end of the casemate in lot 2E12Q6 (Fig. 17), excavation was carried to an average depth of 119.7 ft. A.S.L. This exposed the inlet for drain no. 1 which can be seen in Operation 2E19. The drain runs through a channel cut in the south wall of the casemate, which, when it enters the casemate, is 0.7 ft. wide and 0.76 ft. high. The opening was floored by a wooden plank 0.55 ft. wide and 0.1 ft. thick.

There are no signs of wooden sides or top for this drain. The channel was filled with very sandy clay, 5YR 4/3; reddish-brown, which is similar to the soil of the rest of the lot. The wall through which the channel cuts is more loosely built than the rest of the south interior wall of the casemate.

The channel within the wall could not be completely cleared but it was partially clear when found. No artifacts were found in the drain, though a pair of scissors was found next to the interior wall of the casemate.

This drain must have drained the interior of the casemate, but there is no connection between it and the brick drain, and it is well below the floor level of casemate. It is possible that the drain was built at the wrong level and then abandoned.

The Floor of the Casemate

The floor structures in the east end of the casemate have almost entirely disappeared, in contrast with the good state of preservation of the sleepers in the west end of the casemate, which are discussed by M. Gusset in his 1968 report. When excavation was first completed in suboperation 2E12B, the outline of sleeper beams running north-south and planking running east-west could be seen. No spacing of beams could be made. Four patches of wood fragments were found in the east and central thirds of the casemate at an average elevation of 122.21 ft. A.S.L. The grain in these areas ran generally east-west and the areas may have been deteriorated planking.

Bricks

Two main types of bricks were found in the casemate. Both sizes were reddish in colour, though there were many variations in colour:

Smaller size - occurring in upper layer of intact portion of vault.

- | | | | |
|----|-----------------------------|----------------------|-----------|
| 1. | Peak distribution length | 0.62 ft. | (Table 1) |
| | Average length | 0.63 ft. | |
| | Varying from | 0.56 ft. to 0.69 ft. | |
| 2. | Peak distribution width | 0.30 ft. | (Table 2) |
| | Average width | 0.33 ft. | |
| | Varying from | 0.23 ft. to 0.35 ft. | |
| 3. | Peak distribution thickness | 0.15 ft. | (Table 3) |
| | Average thickness | 0.16 ft. | |
| | Varying from | 0.12 ft. to 0.21 ft. | |

Larger size - occurring in the lowest and middle layers of intact portion of vault.

- | | | | |
|----|-----------------------------|----------------------|-----------|
| 1. | Peak distribution length | 0.70 ft. | (Table 4) |
| | Average length | 0.71 ft. | |
| | Varying from | 0.67 ft. to 0.78 ft. | |
| 2. | Peak distribution width | 0.35 ft. | (Table 5) |
| | Average width | 0.34 ft. | |
| | Varying from | 0.29 ft. to 0.39 ft. | |
| 3. | Peak distribution thickness | 0.20 ft. | (Table 6) |
| | Average | 0.19 ft. | |
| | Varying from | 0.16 ft. to 0.22 ft. | |

It is not possible to establish a historical sequence to the two types of bricks because they were found jumbled together, but bricks similar to those of the smaller size were used in the brick splash drains of the barracks of Operations 2E16 and 2E17, which are later in date than the British Casemate.

Artifacts

The highest concentration of artifacts in the east half of operation 2E12 was in the area of suboperation 2E12K; these included an axe head. Few artifacts were found in the excavations north of the north wall of the casemate. Some arti-

facts were found in the brick drain. Generally the artifacts were of the usual type and seem to be British, late 18th century and early 19th century.

Stratigraphy

Unfortunately the stratigraphic drawings of the excavations that I carried out in Operation 2E12 are not available. However one outline sketch of the drawings done of the north and west faces of suboperation 2E12B is available (Fig. 38).

Layer 10 on the north face (Table 7) and layer 9 on the west face (Table 8) indicate the floor level of the casemate and the deposition of soil on this floor prior to the first collapse of the vault. Layer 8 on both faces shows the extent of the first collapse of the vault and also contains some collapsed stone, probably from the east and south walls of the building. Layer 7 on the north face shows another level of natural deposition following the first collapse of the vault. Layers 6 on the north face and 7 on the west face show another level of collapse of the vault. Layers 4 and 5 on the north face and 5 and 6 on the east face are collapse followed by deposition among the debris. Layer 9 on the north face is heavy leaching of the mortar in the east and north walls of the casemate into the collapse. The deposition of layer 7 on the north face slopes downward from the window opening, indicating that it was deposited through the window, perhaps by wind action. The two separate layers of brick and mortar detritus indicate that the vault collapsed in two stages. Such collapse is quite possible because of the layered construction of the vault.

On the north face layer 2A overlies layers 4 and 5 and therefore layer 2A must be later than 4 and 5. The dense mortar and brick detritus of layer 2A is too high to be collapse from the vault lying as it originally fell. Layers 2 and 3 and 2A were laid down when the modern steps were built

into the casemate. The sequence might have been as follows. An excavation sloping slightly to the west was dug to the level of layer 4 and the brick and mortar detritus found was piled beside the excavation forming layer 2A. Even fill was placed to support the steps, topped by a bedding of sand seen in layer 1 on the west face. This fill formed layer 3 on the north face. Once the steps were finished the rest of the backdirt from the hole was put back. The pile of brick and mortar detritus from the hole and perhaps also from the excavations within the casemate was not spread out but only covered.

Interpretations and Conclusions

When the site of Fort Beausejour was fortified by the French, the curtain wall between what were to be Prince Henry and Prince Edward Bastions contained the main entrance to the fort. In 1752, timber casemates were constructed in the south curtain and the south end of the south east curtain and in the north curtain on either side of the entrance (Nadon 1966: I: 1). During the seige of 1755, one of the casemates beside the entrance, which were described as "bombproof", was hit and the occupants killed (Nadon 1966: I: 1).

After the seige the curtain wall and the casemates were levelled and the main entrance built in the curtain between Prince Frederick and Prince William Bastions. New stone casemates were built between Prince William and Duke of Cumberland Bastions and between Prince Edward and Prince Henry Bastions. In 1758 work was still going on on the casemates (Nadon 1966: C: 4), but it must have been finished before 1761, when the casemates were described as being in good condition (Nadon 1966: C: 5).

The casemate between Prince Henry and Prince Edward Bastions is described (Nadon 1966: I: 5) as being 10 ft. wide,

8 ft. high "to the keystone" and 6 ft. high to the spring. The vault was 1.5 ft. thick, with 3 ft. to 4 ft. of soil above its walls and the four twelve pounders of Loudoun's Battery above that. The floor of the casemate was two feet below the level of the parade. The interior was lined and arched in brick and divided into two parts by a brick wall, one part containing two beds for guardsmen. The interior was damp.

In 1776 the powder magazine in the spur was so deteriorated that the fort's supply of powder was moved to one of the casemates within the fort (Nadon 1966: C: 5). By 1783 one of the casemates was in ruins (Nadon 1966: C: 6). In 1925, in connection with the site of Fort Beausejour being made a National Historic Park, excavation was done in the area of the casemate covered by the standing portion of the vault and masonry retaining walls with concrete lintels were built at each end of this area. A window was included at the west end and masonry steps at the east end. The area had always been open to visitors to the site.

The casemate excavated as Operation 2E12 is definitely the casemate built by the British after they captured the fort. The dimensions given for the interior nearly correspond to the building as excavated. The discrepancy in the thickness of the vault is probably because the vault would have been completely or partly closed in.

However, no recognizable trace of a brick lining was found. This might have been salvaged before the casemate was abandoned, but it is unlikely that all trace of it and its substructure would have disappeared. That the stone of the walls was fairly well finished and then coated with rough cast, which was then carved with initials and names, seems to indicate that this and not brick was the interior finish. No sign of a brick dividing wall was found in the east and

central thirds of the casemate. The presence of sleeper beams at the west end of the building seems to preclude its being there. It could have been located at the east end of the area containing the sleepers (Fig. 17), approximately under the west end of the standing portion of the vault. An interior partition at this point would explain the difference in the state of the preservation of the flooring, since the flooring of a guardroom would be more likely to be renewed than that of a storeroom.

The casemate to which the fort's powder supply was removed in 1776 may have been this one since the loopholes in the curtain wall backing the casemate between Prince William and Duke of Cumberland Bastions would have made that location extremely vulnerable during an attack. But the 2E12 casemate was damp.

The recorded date does not make any mention of the two fireplaces in the south wall of the casemate or of the brick drain complex.

It is apparent that when the casemate was first built it had two entrances. The east entrance, probably spanned by a beam, was reached by three steps down from the level of the parade, through the gorge of Prince Henry Bastion. At some time during the occupation of the building, this entrance was blocked by four courses of stone, topped by a window with a brick ledge. Probably at the same time, the steps were filled with garbage and covered over.

Probably during the later phases of construction of the casemate or shortly after the end of construction, the east wall was extended to the north into the curtain wall to act as a retaining wall to prevent collapse of the fill supporting Loudoun's Battery into the gorge of Prince Henry Bastion. That the extension and the east wall are bonded in the upper courses, indicates that construction had not finished on the

main part of the wall when the extension was begun. Since the south wall of the casemate is not completely capped by the spring of the arch, it could have risen a few courses higher containing the flues of the two fireplaces. These flues would have risen above the wall to get a proper draw.

The casemate was finally rendered useless by the collapse of the vault. The vault collapsed in two phases, the time between the two collapses being long enough to allow for natural deposition on the interior. The fireplace at the east end of the building seems to have been intentionally filled from above with rubble, probably from the south wall. This may have occurred after the collapse of the vault when the hole in the top of the south wall would have been dangerous to anyone walking along the top of the wall. Some of the stone from the walls fell into the interior, and some, from the east wall fell into the gorge of Prince Henry Bastion. Unfortunately the exact date of the abandonment and collapse of the casemate is not known.

The Continuation of Excavation in Operation 2E20

Late in the summer of 1968, excavation was resumed in Prince Frederick Bastion, which had been largely excavated in 1967. Excavation was continued in the well, Suboperation 2E20K and in Suboperation 2E20R (Fig. 39) to determine whether there were any structures earlier than the stone built casemate in this area.

The clearing of the well, using a shaker screen to check for artifacts was continued through two arbitrary lots, 2E20K11 and 2E20K12, each approximately 1 ft. thick with the same horizontal dimensions as the well. These are a continuation of the excavation units set up in 1967.

Suboperation 2E20R, consisting of two lots 2E20R1 and 2E20R2, is bounded on the south by the south side of the rubble wall which is the north limit of 2E20M, on the east side of the rubble wall that forms the west limit of 2E20J, and on part of the north side by a section of the exterior wall of the well. The dimensions of the suboperation are 5 ft. north-south and 11.5 ft. east-west. The average surface elevation of 2E20R was 127.32 ft. A.S.L. Lot 2E20R1 covered the horizontal area of the suboperation and its average base elevation was 120.72 ft. A.S.L. Lot 2E20R2 covered the west two-thirds of the suboperation with an average base elevation of about 119.9 ft. A.S.L.

No new structural features were exposed by the excavations in 2E20R. But the excavations did expose the east side of the west wall of 2E20J (Fig. 40) and the south side of the north wall of 2E20M (Fig. 41). Both these walls are built of roughly coursed rubble. A portion of the exterior wall of the well was further exposed; it is also built of roughly

coursed rubble.

A great many artifacts, which seem to be mostly British of the late 18th century and early 19th century, were found in the well which indicates that it was used as a garbage dump.

No artifacts were found in Suboperation 2E20R, but several modern tin cans were found that show that part of this area was excavated by Rick in 1962.

Unfortunately the stratigraphy drawing down of the north face of 2E20R are not available. The soil in lots 2E20K11 and 2E20K12 was loamy, 10YR 3/4, dark yellowish-brown. The soil in 2E20R1 and 2E20R2 was sandy clay, 5YR 4/4, reddish-brown.

Excavations in Suboperation 2E23B

Excavation was carried out in Suboperation 2E23B to determine the nature of a mound in the parade square, south of the 2E19 Barracks (2E-1522 X). The Suboperation was 20 ft. east-west by 5 ft. north-south. The location was determined by triangulation from the southeast exterior corner of the 2E19, Point A, and from the southwest corner of the Counterfort No. 4 on the North Stone Wall, Point B, to the northeast corner of 2E23B, Point 1, and to the northwest corner of 2E23B, Point 2.

Point A to Point 1 - 8.8 ft. to Point 2 - 24 ft.

Point B to Point 1 - 30.8 ft. to Point 2 - 30.8ft.

The Suboperation consisted of four lots; 2E23B1, being the sod layer, and 2E23B2 to 2E23B4. The average elevation of the base of excavation in 2E23B was 125.4 ft. A.S.L.

Features

In the sod layer of the Suboperation a piece of dressed red sandstone was uncovered which had been partially exposed previously. However, this did not relate to any feature found during excavation.

During excavation a wall, running southwest-northeast was uncovered (2E-1520 X). This was mostly rubble but at its north end two courses were standing to a height of 1.39 ft. above the final excavation floor. The average surface elevation of 126.64 ft. A.S.L., with a maximum elevation of 126.73 ft. A.S.L. The width of the wall could not be measured because of its deteriorated condition; its exposed length is 6.1 ft.

A great deal of rubble was found along the south side of

the suboperation which does not seem to relate to the wall.

East of the wall a great deal of brick detritus was found which did not contain any whole bricks. These seem to be building debris and its base represents a previous ground level. The average elevation of its base was 126 ft. A.S.L.

The brick detritus was removed, uncovering beneath it and adjacent to the east side of the wall, a rubble pavement. The feature is exposed across the width of the suboperation. The average elevation of its upper surface was 125.79 ft. A.S.L. The pavement is 0.75 ft. thick. The upper surface of the pavement roughly corresponds to the ground level represented by the brick detritus.

The artifacts found in the suboperation are of the usual sort and appear to be British of the late 18th century and early 19th century.

Stratigraphy

Excavation was not continued in suboperation 2E23B, so no stratigraphy drawings were done. However the soil types in each lot were as follows: 2E23B1 and 2E23B2, loam with brick detritus, 10YR 3/4, dark yellowish-brown 2E23B3, sandy clay, 7.5 YR 4/2 dark brown; 2E23B3, sandy loam, 5YR 4/4 reddish brown. The difference between lots 2E23B3 and 2E23B4 is due to deposits on either side of the wall before its collapse or removal. Lots 2E23B1 and 2E23B2 are layers deposited after the collapse or removal of the wall.

Interpretation and Conclusions

The excavations designated suboperation 2E23B indicated that the mound in the parade square south of the 2E19 barracks was made up of brick detritus, which covered a portion of a ruined wall that may have belonged to a number of structures that

were located in the parade square at various times, perhaps a drive shed.

References Cited

Coleman, K.

1966

"Report on the Excavations of the 2E16 Men's Barracks."
Manuscript on file, National Historic Parks and Sites Branch,
Ottawa.

Korvemaker, Frank

1967

"Report on the Excavation of the 2E16 Men's Barracks."
Manuscript on file, National Historic Parks and Sites Branch,
Ottawa.

Macdonald, Pat

1967

"Report on the Excavation of the 2E17 Officer's Barracks."
Manuscript on file, National Historic Parks and Sites Branch,
Ottawa.

Nadon, Pierre

1966

"Historical Report on Fort Beausejour." Manuscript on file,
National Historic Parks and Sites Branch, Ottawa.

1968

"Technical Report on Fort Beausejour." National Historic
Parks and Sites Branch, Ottawa.

Zeller, A.

1968

"Excavation of Drainage System at Fort Beausejour." Manuscript
on file, National Historic Parks and Sites Branch, Ottawa.

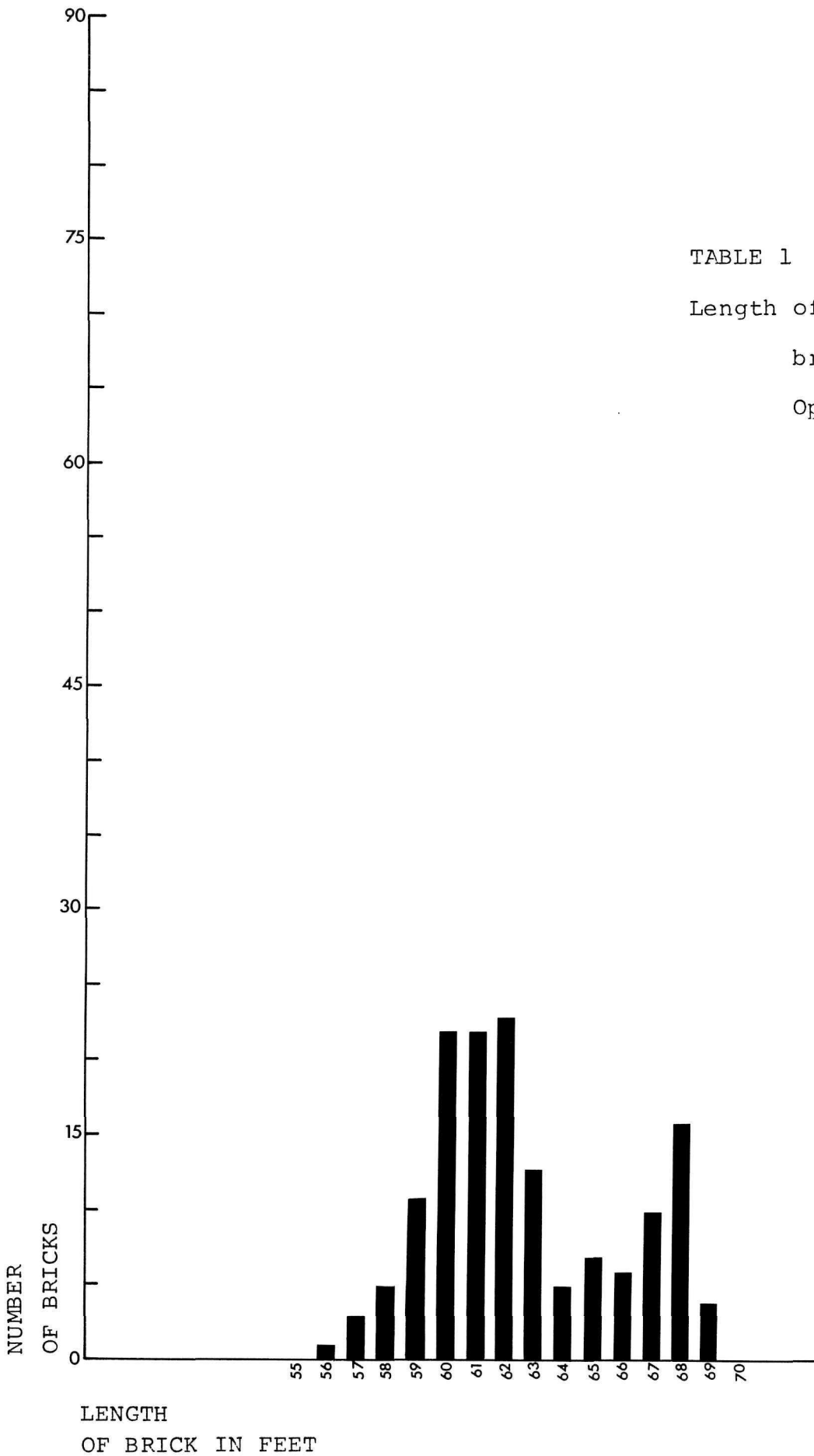

TABLE 1
Length of the smaller
bricks in
Operation 2E12

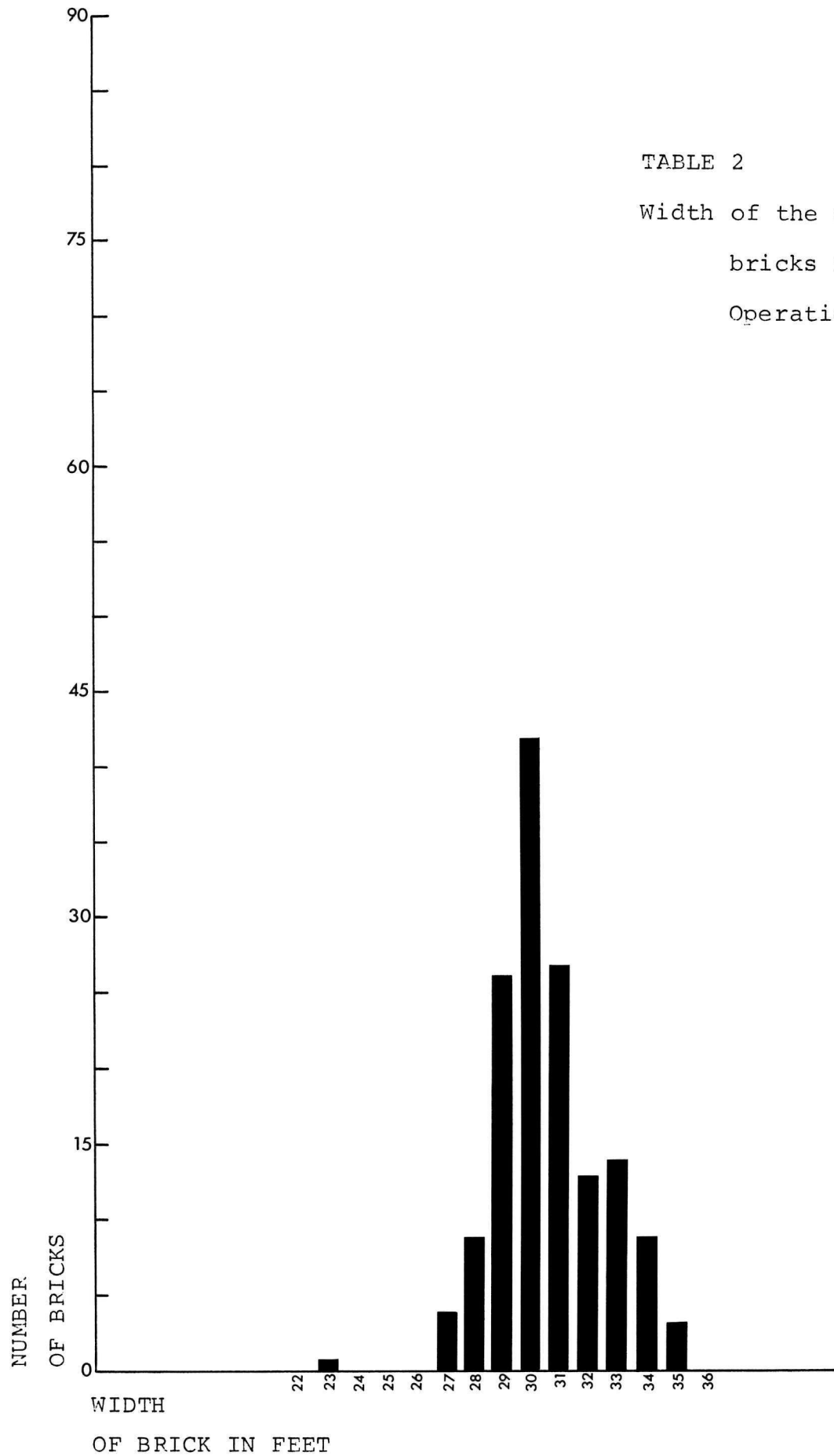

TABLE 3

Thickness of the smaller
bricks in
Operation 2E12

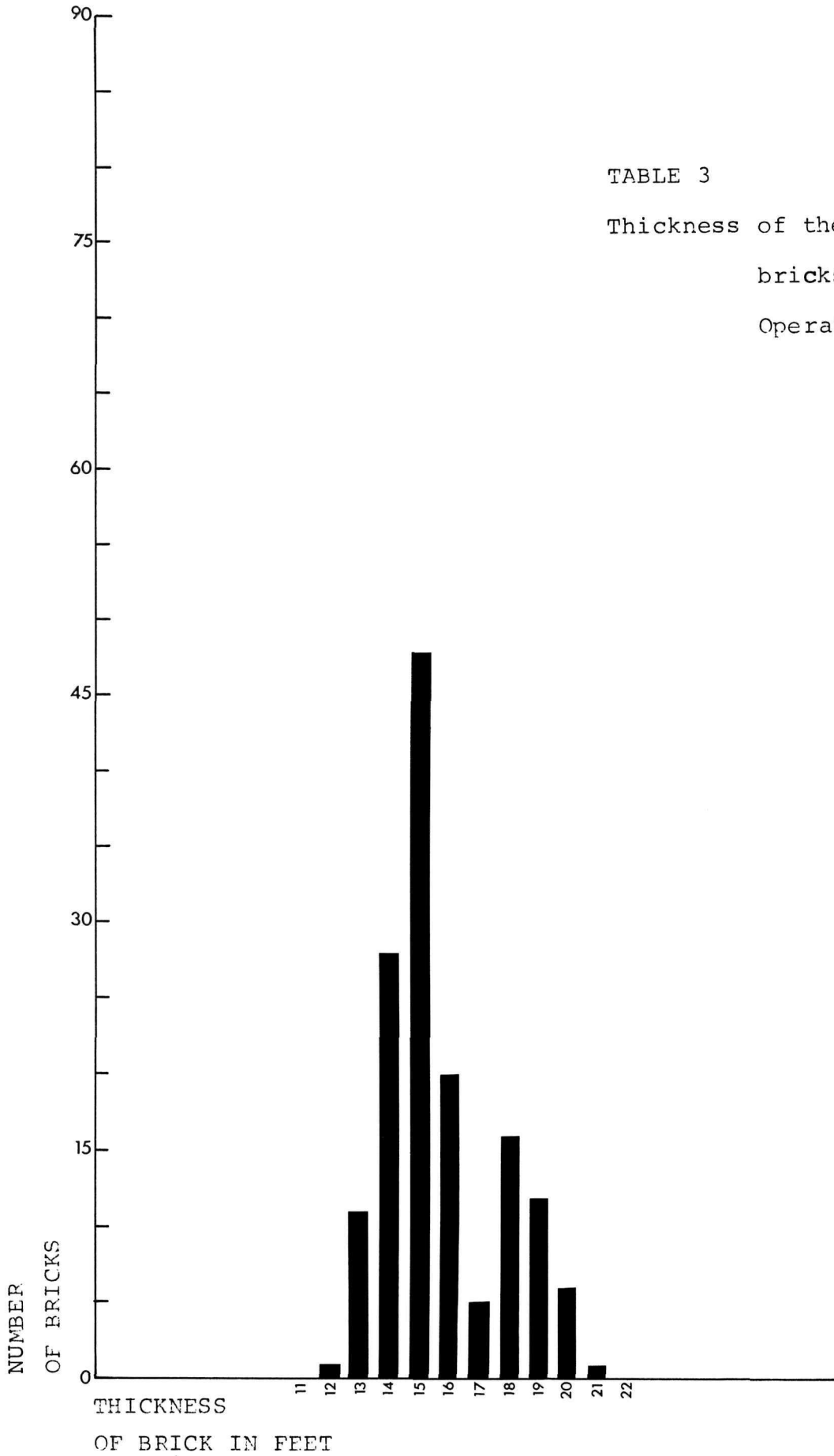

TABLE 4

Length of the larger
bricks in
OPERATION 2E12

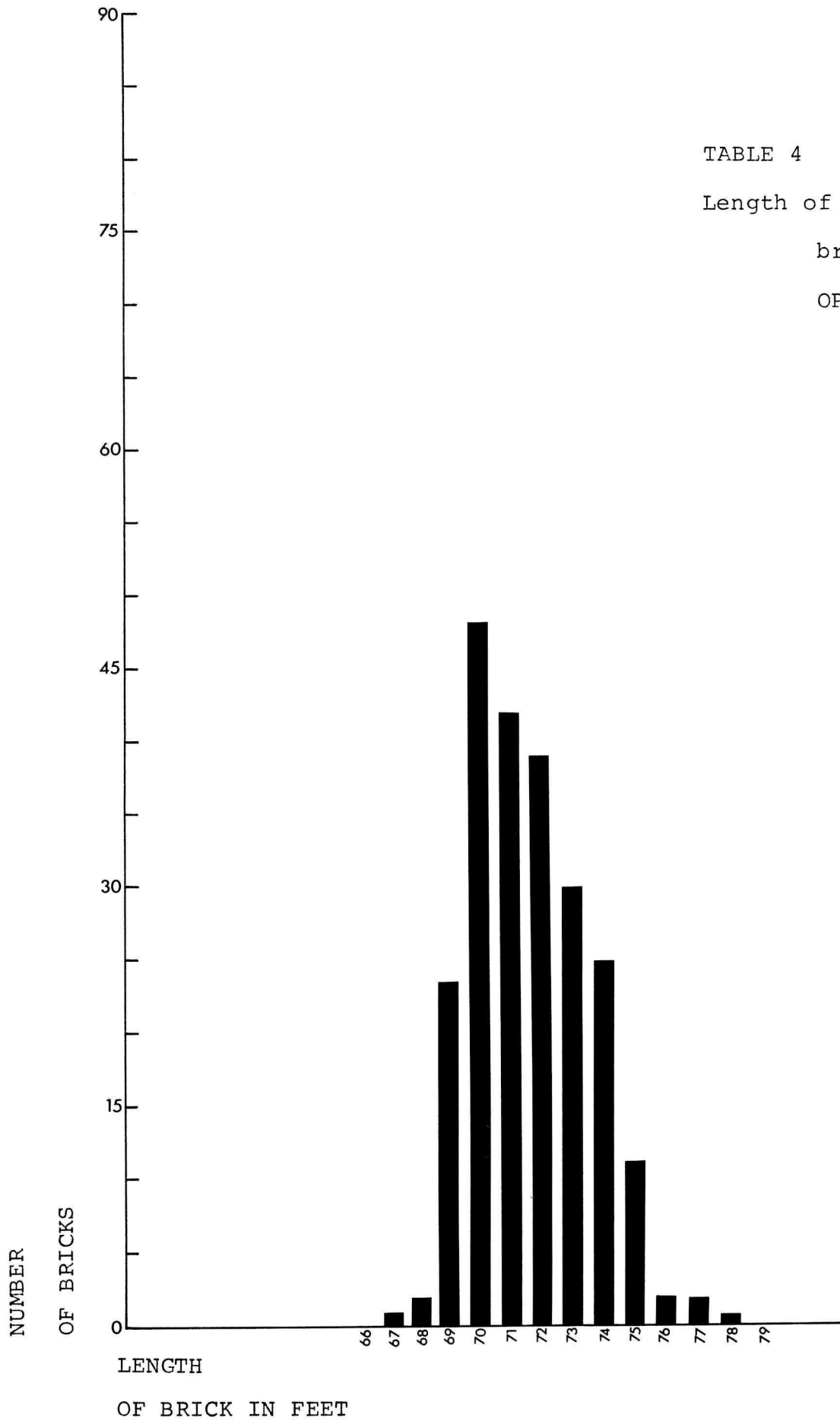
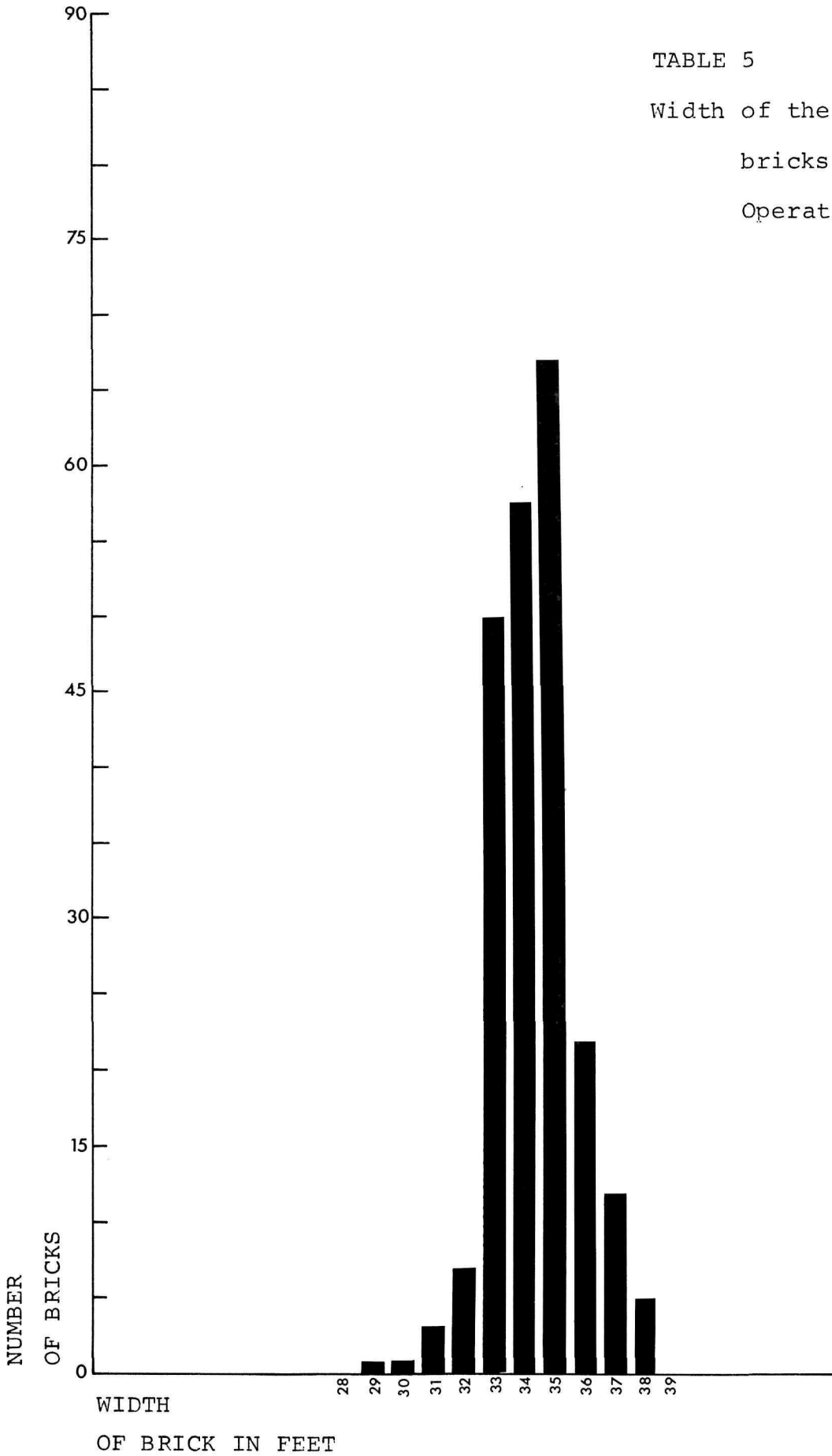

TABLE 5
Width of the larger
bricks in
Operation 2E12



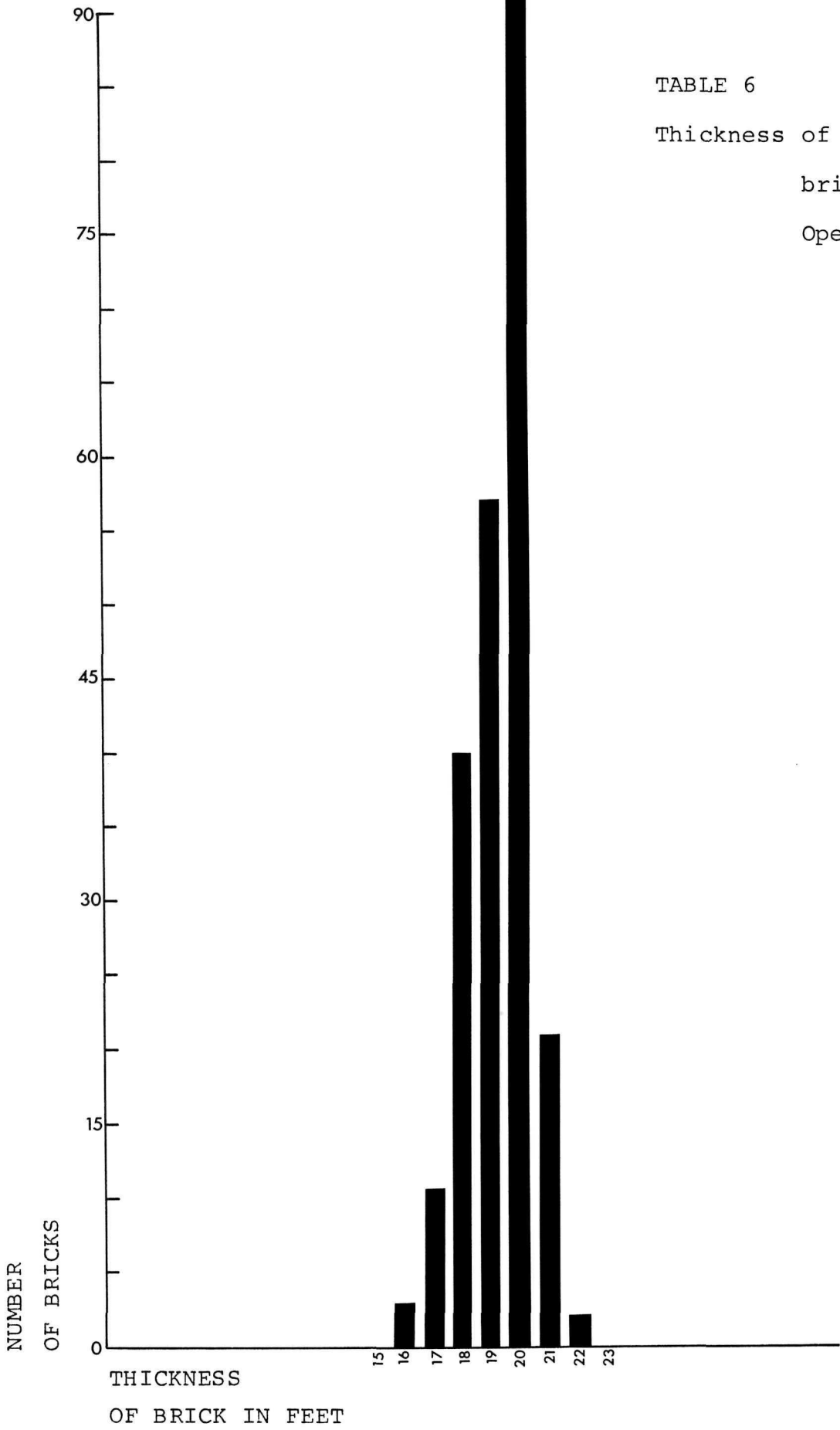

TABLE 6
Thickness of the larger
bricks in
Operation 2E12

Table 7

Soil stratigraphy layers on the north face of 2E12B:

- Layer 1 10YR 5/3, brown sandy loam; sod layer.
- 2 7.5 YR 4/4, dark brown, sandy loam; brick and mortar detritus.
- 2A 7.5 YR 4/4 dark brown, sandy loam; dense brick and mortar detritus.
- 3 5YR 4/4 reddish brown, sandy loam; brick and mortar detritus.
- 4 7.5YR 4/4 dark brown, sandy clay; brick and mortar detritus.
- 5 7.5YR 4/4 dark brown, sandy loam; brick and mortar detritus.
- 6 7.5YR 4/4 dark brown, sandy loam; dense brick and mortar detritus.
- 7 7.5YR 4/4 dark brown, sandy clay.
- 8 7.5YR 4/2 brown, sandy clay; dense mortar and brick detritus.
- 9 10YR 7/2 light grey, sand; heavy mortar leaching.
- 10 10YR 4/3 dark brown, clay; wood fragments.

This drawing also included layers 11, 12 and 13, but these cannot be described beyond that they were outside the east wall of the casemate and included brick and mortar detritus and loose stone.

Table 8

Soil stratigraphy layers on the west face of 2E12B:

- Layer 1 10YR 4/4 dark yellowish brown, sand.
- 2 7.5YR 4/4 dark brown, sandy loam.
- 3 5YR 4/4 reddish brown, sandy clay; brick and mortar detritus with lens of mortar.
- 4 5YR 4/3 reddish brown, sandy clay; some brick and mortar detritus.
- 5 5YR 4/4 reddish brown, sandy clay; some brick and mortar detritus.
- 6 5YR 3/4 dark reddish brown, sandy clay.
- 7 7.5YR 4/4 dark brown, sandy loam; brick and mortar detritus.
- 8 7.5YR 4/2 dark brown, sandy clay; brick and mortar detritus.
- 9 7.5YR 4/2 dark brown, clay; wood fragments.

Table 9

Coordination of the soil stratigraphy layers of the north and west faces of 2E12B.

<u>North Face</u>	<u>West Face</u>
Layer 1	---
Layer 2	Layers 1 and 2
Layer 2A	---
---	Layer 3
Layer 3	Layer 4
Layer 4	Layer 5
Layer 5	Layer 6
Layer 6	Layer 7
Layer 7	---
Layer 8	Layer 8
Layer 9	---
Layer 10	Layer 9
Layer 11	---
Layer 12	---
Layer 13	---

Table 10

Lot-Layer Correlation

The layers laid down when the modern steps into the intact portion of the casemate were built were included in lots 2E12B1 and 2E12B3.

The debris associated with the floor level of the casemate and the deposition on it prior to the first collapse of the vault were included in lot 2E12B6.

The first collapse of the vault was contained in lots 2E12B3, 2E12B4 and 2E12B5.

The natural deposition after the first collapse of the vault and prior to the second collapse of the vault was included in lots 2E12B3 and 2E12B4.

The debris from the second collapse of the vault was included in lots 2E12B3 and 2E12Br.

The natural deposition following the second and final collapse of the vault was included in lots 2E12B1, 2E12B3 and 2E12B4.

Debris from the collapse of the exterior structure of the casemate was included in lots 2E12B3 and 2E12F12.

Lot-Layer correlation of the soil stratigraphy layers on the north and west faces of 2E12B.

Lot	West Face	North Face
2E12B1	Layers 1 and 2 Top of Layers 3 and 4	Layers 1, 2, 2A Top of layers 3, 4, 5, 6
2E12B3	Bottom of Layers 3, 4 Layer 5 Top of Layers 6, 7	Bottom of layers 3, 4, 11 Middle of layers 5, 6 Top of layers 7, 8
2E12B4	Bottom of layers 4, 5, 6, 7 Top of layer 8	Bottom of layers 5,6,7 Middle of layer 8 Top of layer 9
2E12B5	Bottom of layer 8 Top of layer 9	Bottom of layers 8, 9 Top of layer 10
2E12B6	Bottom of layer 9	Bottom of layer 10
2E3F12		Layers 11, 12, 13

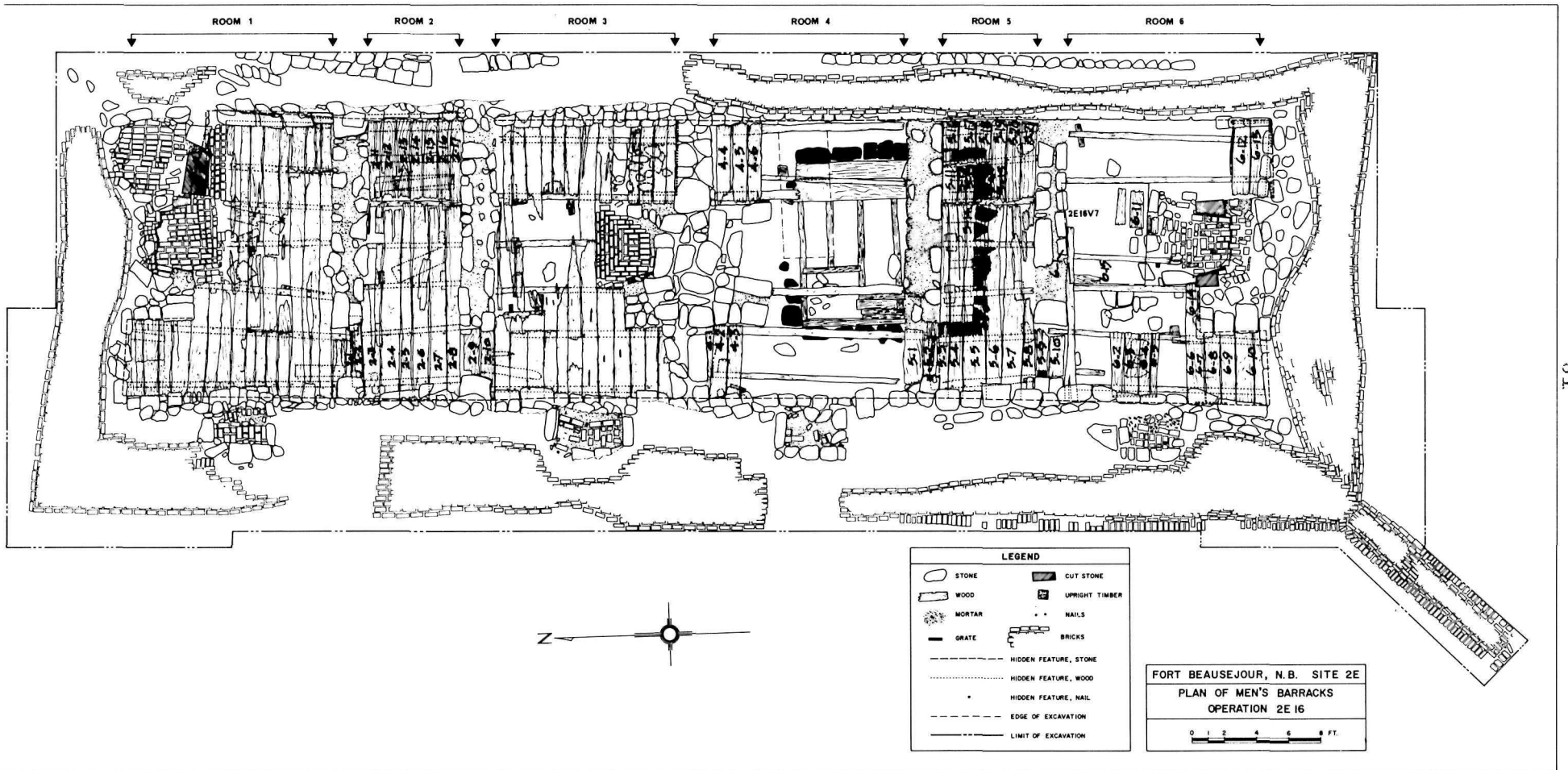

1 Floor plan of Men's Barracks 2E16. (2E-66-102-14)

FIGURE 2

Diagram of the sub-floor structure, 2E16Y1, not to scale

Y1-1 to Y1-20 are planks or fragments of planks

1 to 6 are beams

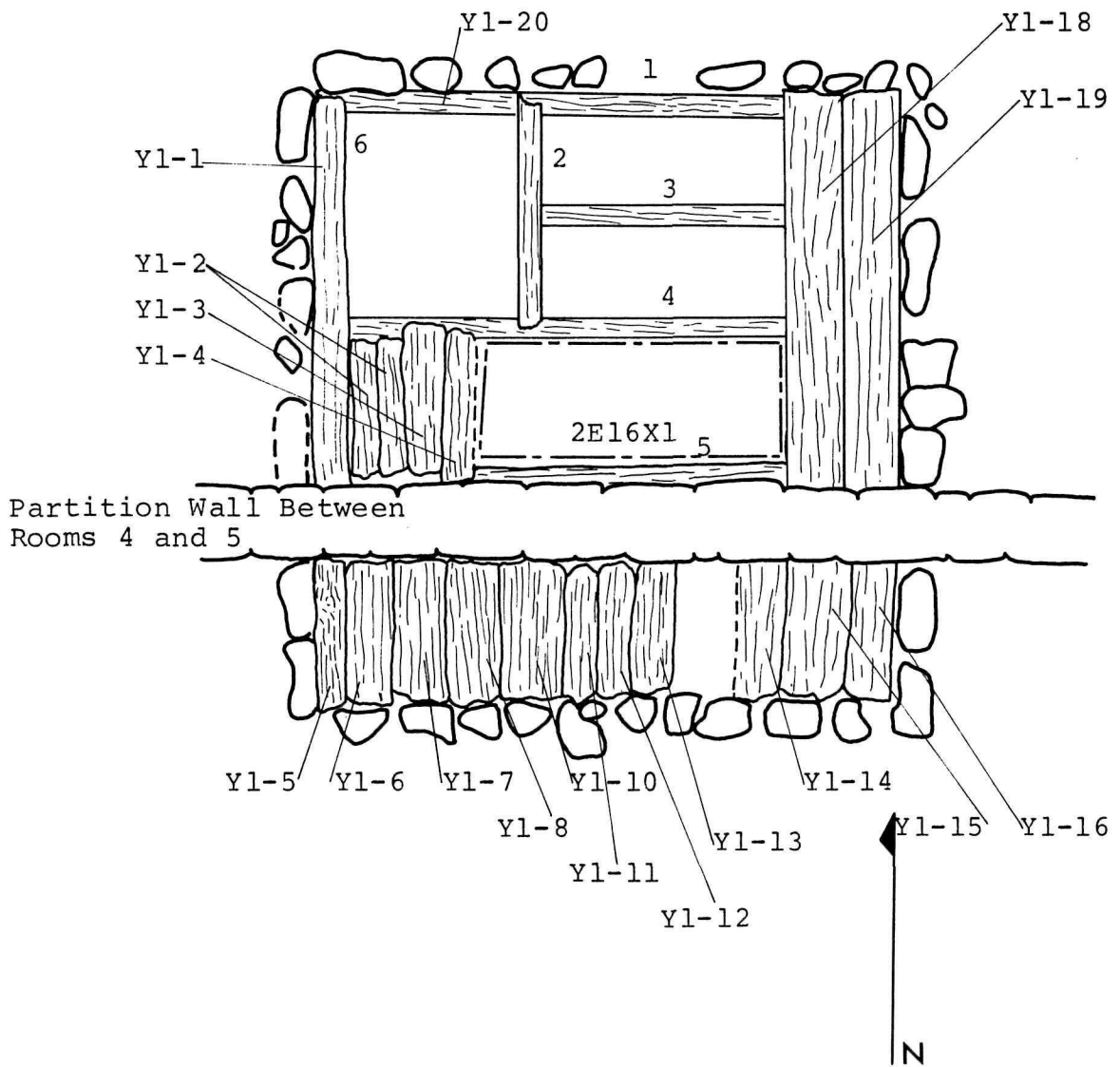

FIGURE 3

Diagram of the planking of 2E16Y1 showing the slope of the planking and the partition wall between Rooms 4 and 5, not to scale, looking east.

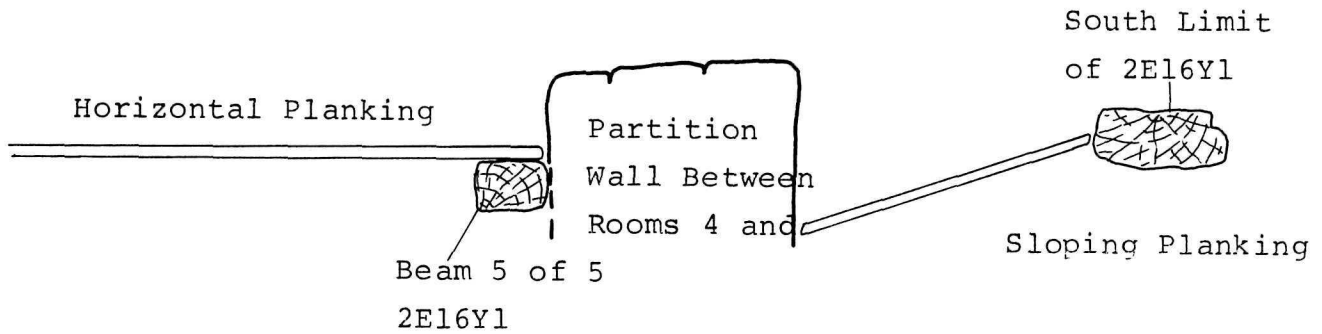

FIGURE 4

Diagram of the notching of the beams in 2E16Y1, not to scale.

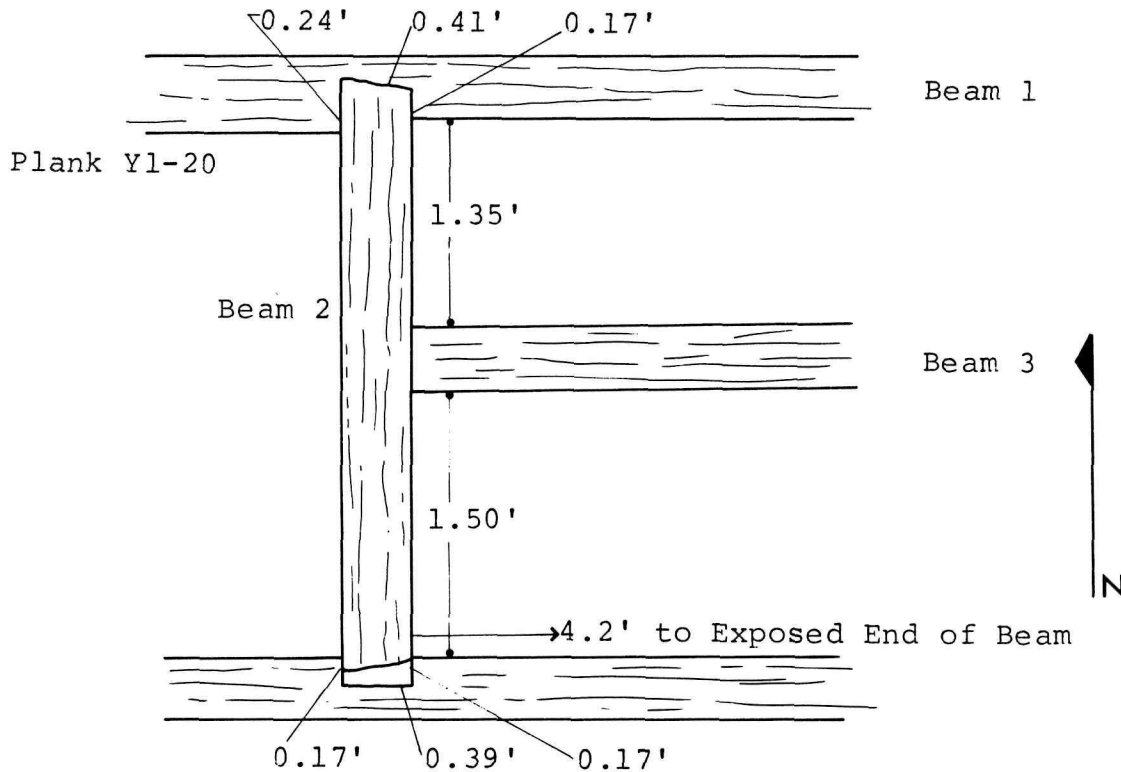

FIGURE 5

Diagram of the Section of Drain #3 found in Room 4, lot 2E16V4 not to scale.

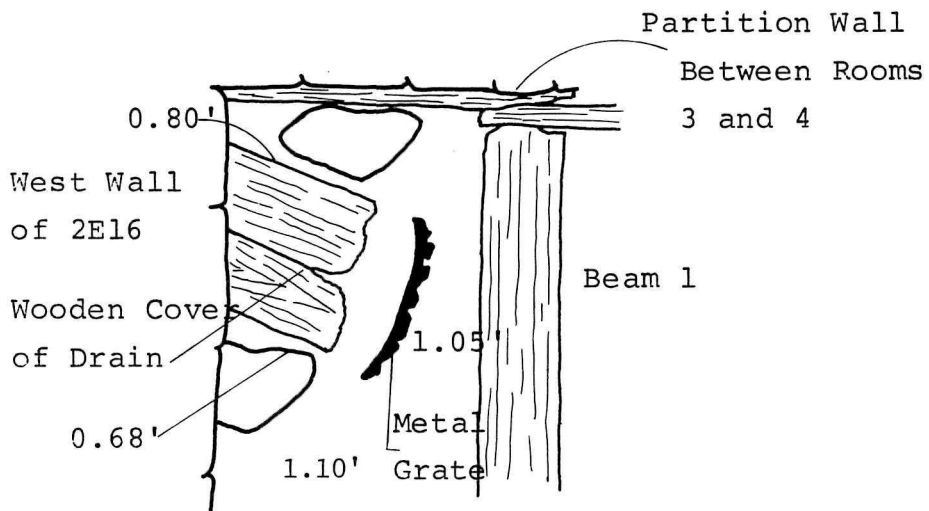
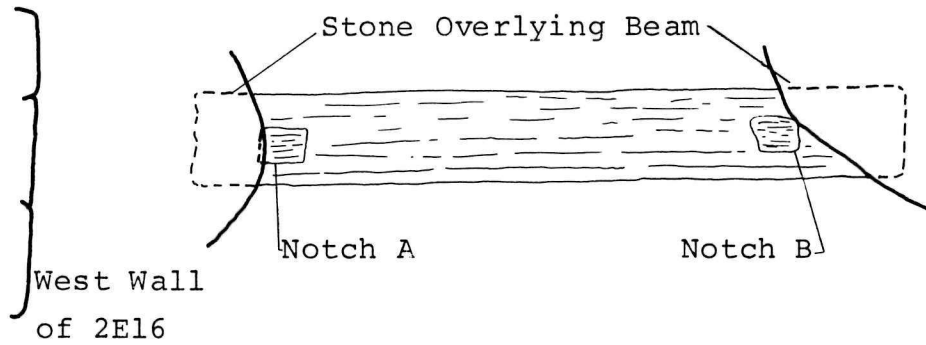

FIGURE 6

Diagram of Beam 8 of Room 2 of the 2E16 Barracks, not to scale.



BEAM 8

PLAN VIEW

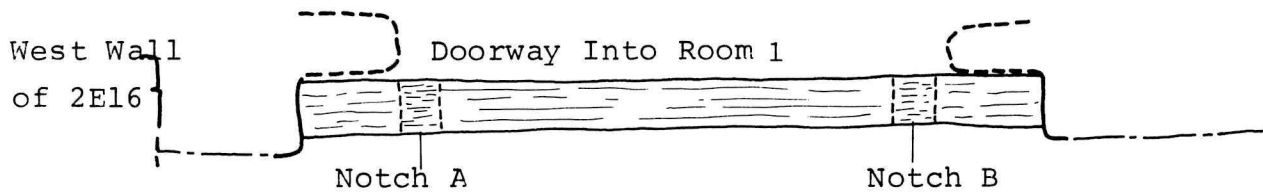

BEAM 8

SIDE VIEW

LOOKING NORTH

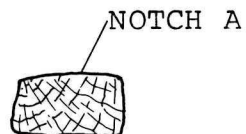

BEAM 8

END VIEW

LOOKING EAST

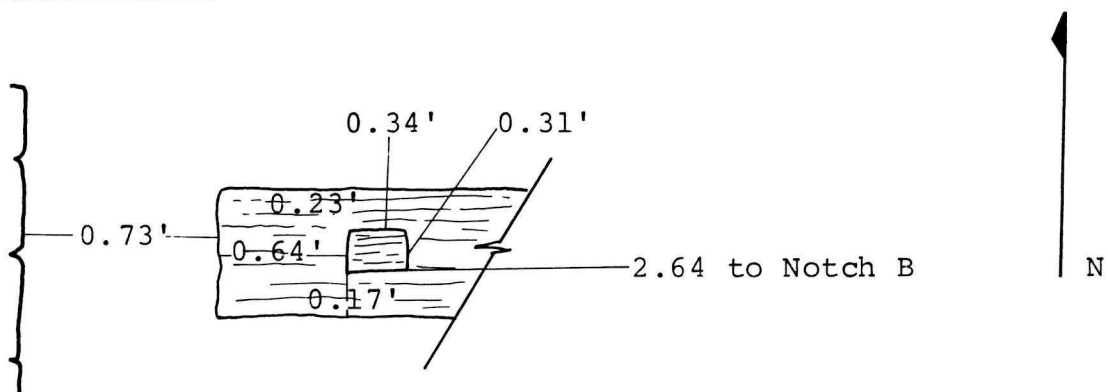
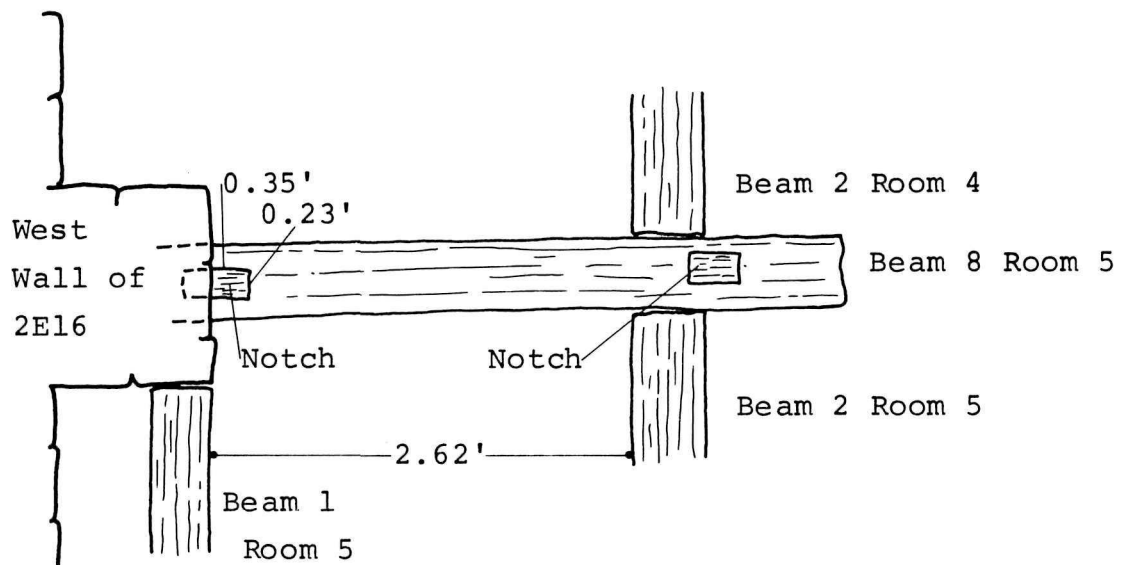

FIGURE 7

Diagram of Beam 8 of Room 5 of the 2E16 Barracks, not to scale.



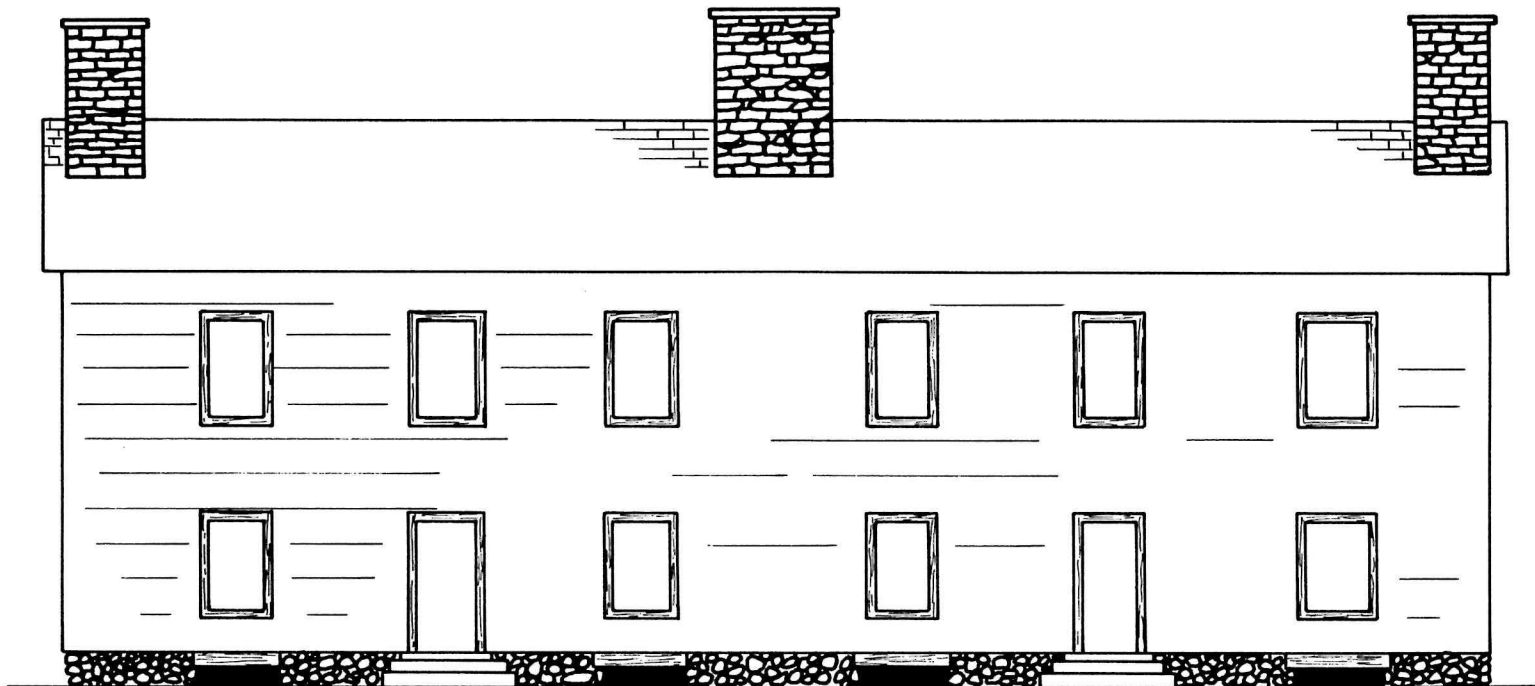
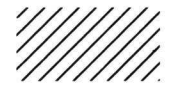



FIGURE 8

Elevation view of a tentative reconstruction of the 2E16 Mens Barracks, facing east, not to scale.

9 The 2E17 Floor Plan (2E-67-102-5)

 FLOOR STRUCTURES
 REMOVED DURING
 THE 1968 EXCAVATIONS

 EARLY WALLS

 WALL STRUCTURES
 REMOVED DURING
 THE 1968 EXCAVATIONS

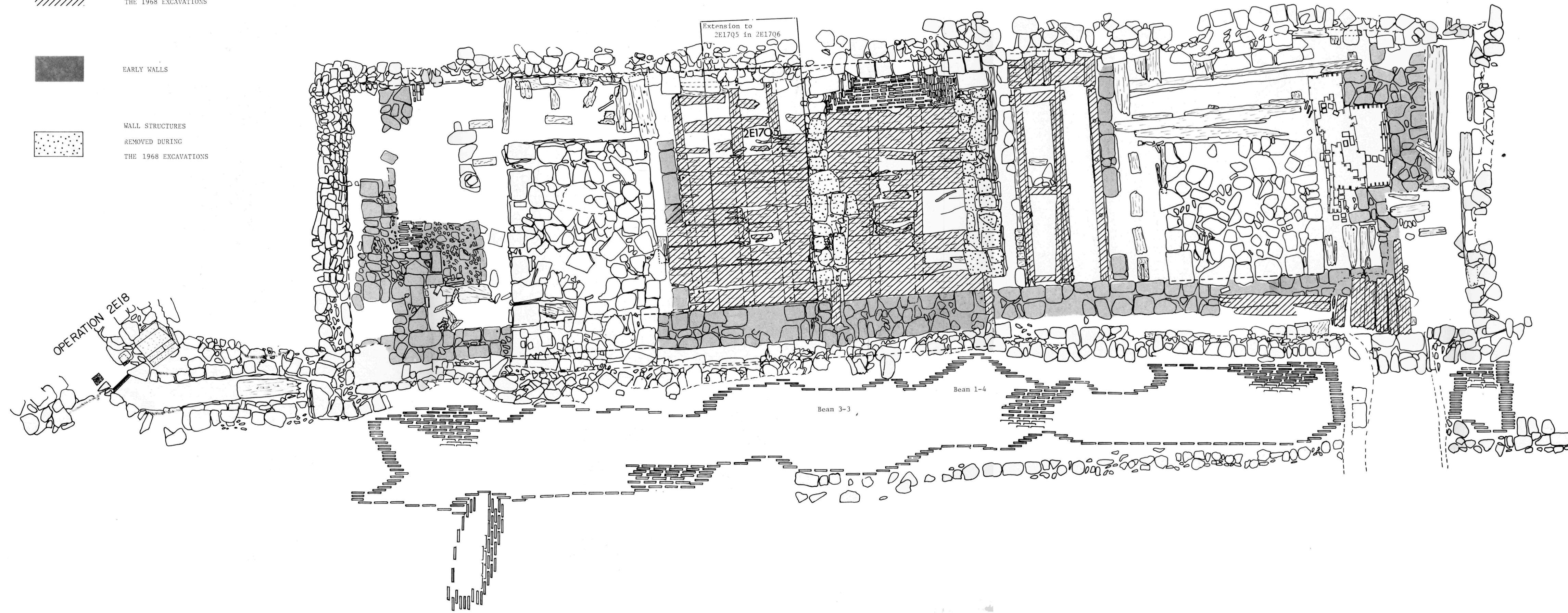
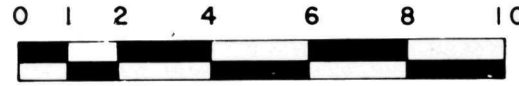





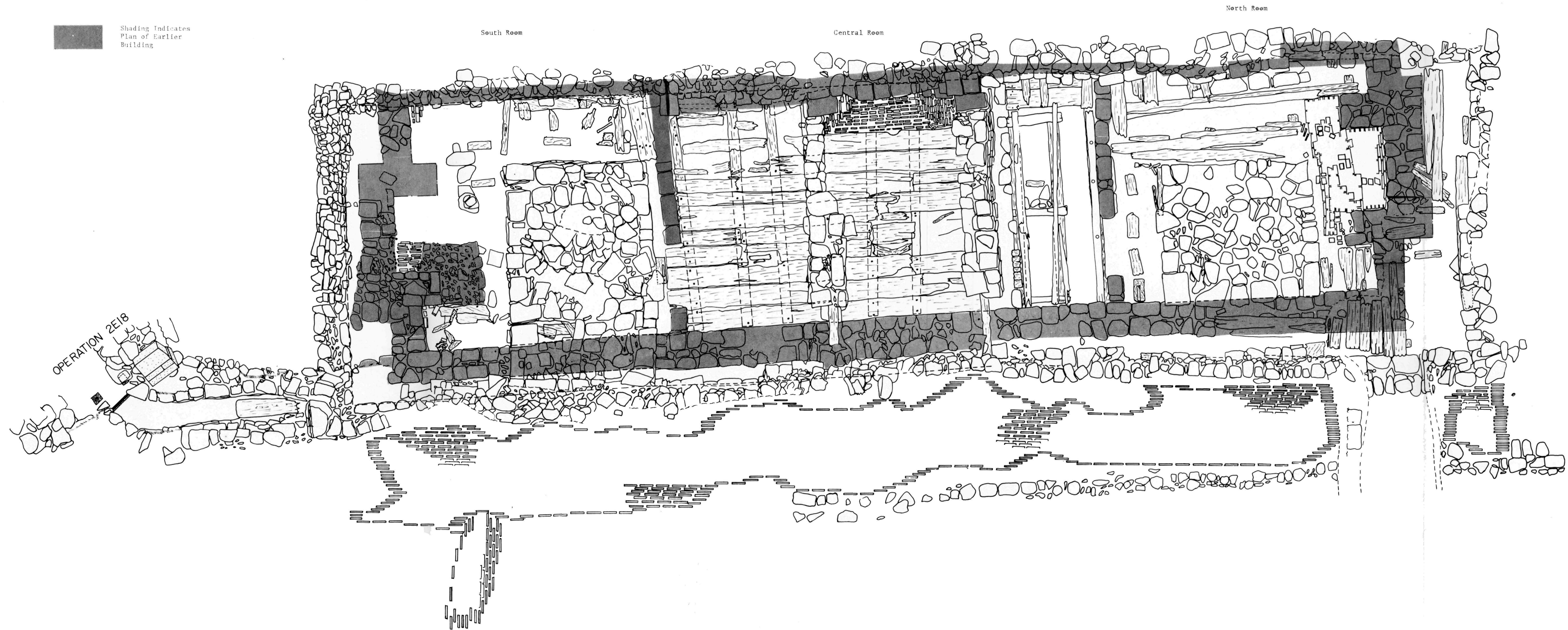

Figure 9

FORT BEAUSEJOUR N.B. SITE 2E	
PLAN OF OFFICERS' BARRACKS	
OPERATION 2E17	
	
LEGEND	
 STONE	 SOIL
 WOOD	 NAILS
 BRICKS	 PEGS

10 Plan of the basement of the earlier building
on the site of 2E17 Barracks. (2E-67-102-5)



Shading Indicates
Plan of Earlier
Building

South Room

Central Room

North Room

Figure 10

FORT BEAUSEJOUR N.B. SITE 2E
PLAN OF OFFICERS' BARRACKS
OPERATION 2E17

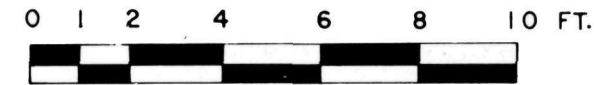

LEGEND			
	STONE		SOIL
	WOOD		NAILS
	BRICKS		PEGS



11 2E17Q5. View of the west wall of the earlier structure.
Camera facing west. 2 ft. scale aligned north-south (2E-3183 X).

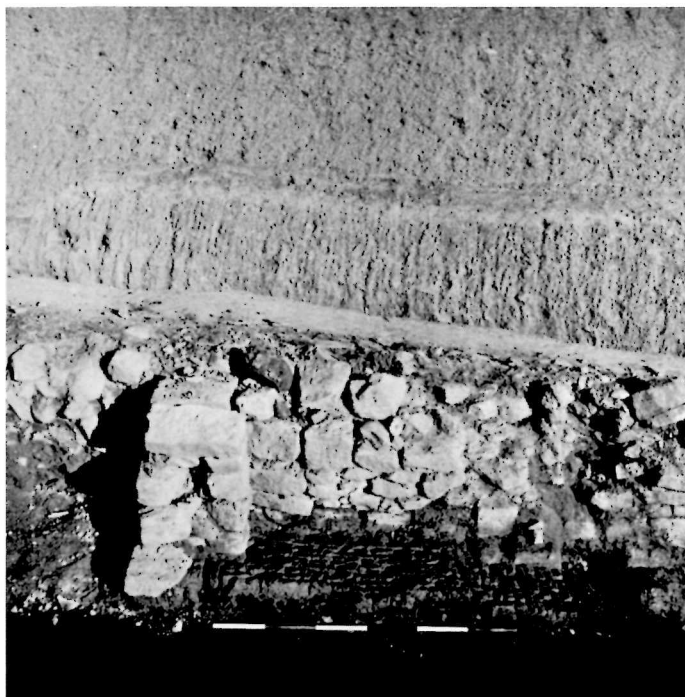

12 2E17Q5. Fireplace on the west wall of the barracks.
Camera facing west. 6 ft. scale aligned north-south (2E-3306 X).



13 Barrel 2E17Q5-1. Camera facing east. 2 ft. scale aligned north-south (2E-3176 X).



14 2E17Q6. Overall shot of barrel. Camera facing east. 2 ft. scale vertical (2E-3242 X).

FIGURE 15

A tentative reconstruction of the ground floor plan of the 2E17 Barracks, not to scale.

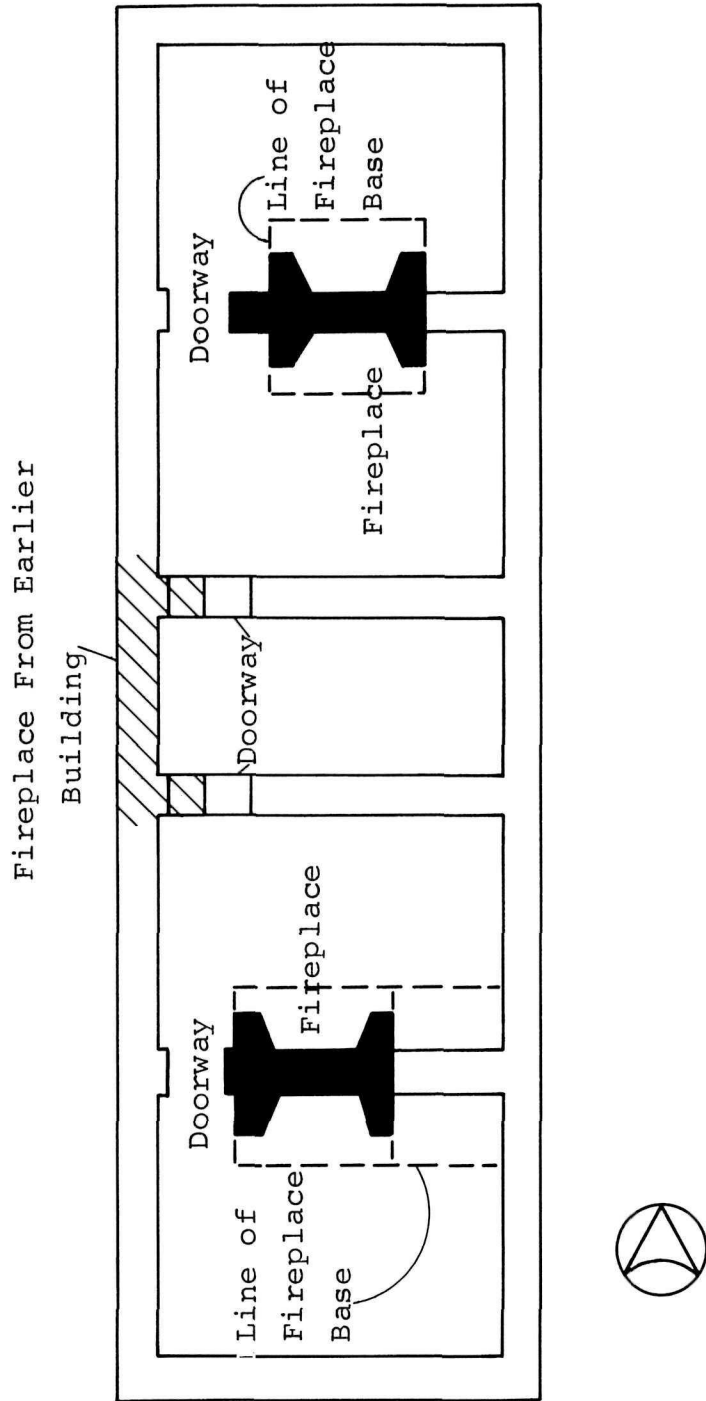



16 Post excavation shot of 2E12F, showing the concrete lintel and the top of the masonry steps into the casemate. Camera facing northwest. 6 ft. scale on top of south wall (2E-1528 X).

17 Site plan of 2E12. (2E-68-109-9)

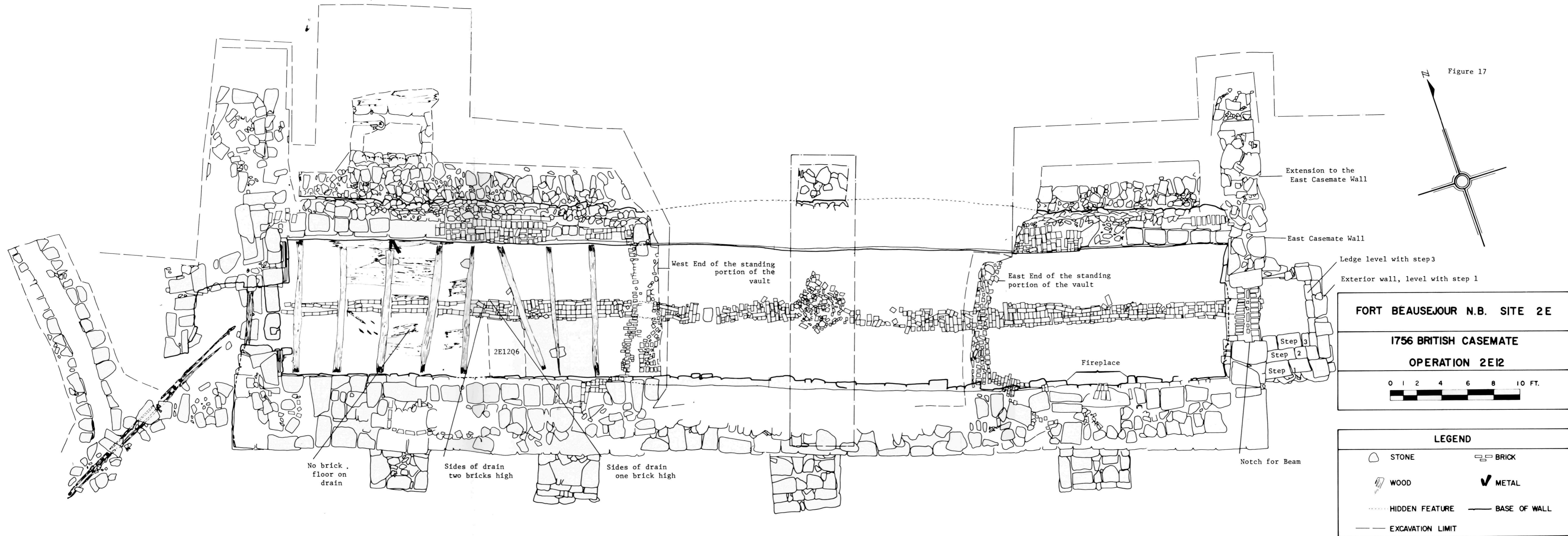

18 Location and dimensions of the suboperation in
 the east half of 2E12, in relation to the
 structures. (2E-68-109-9)

Figure 18b

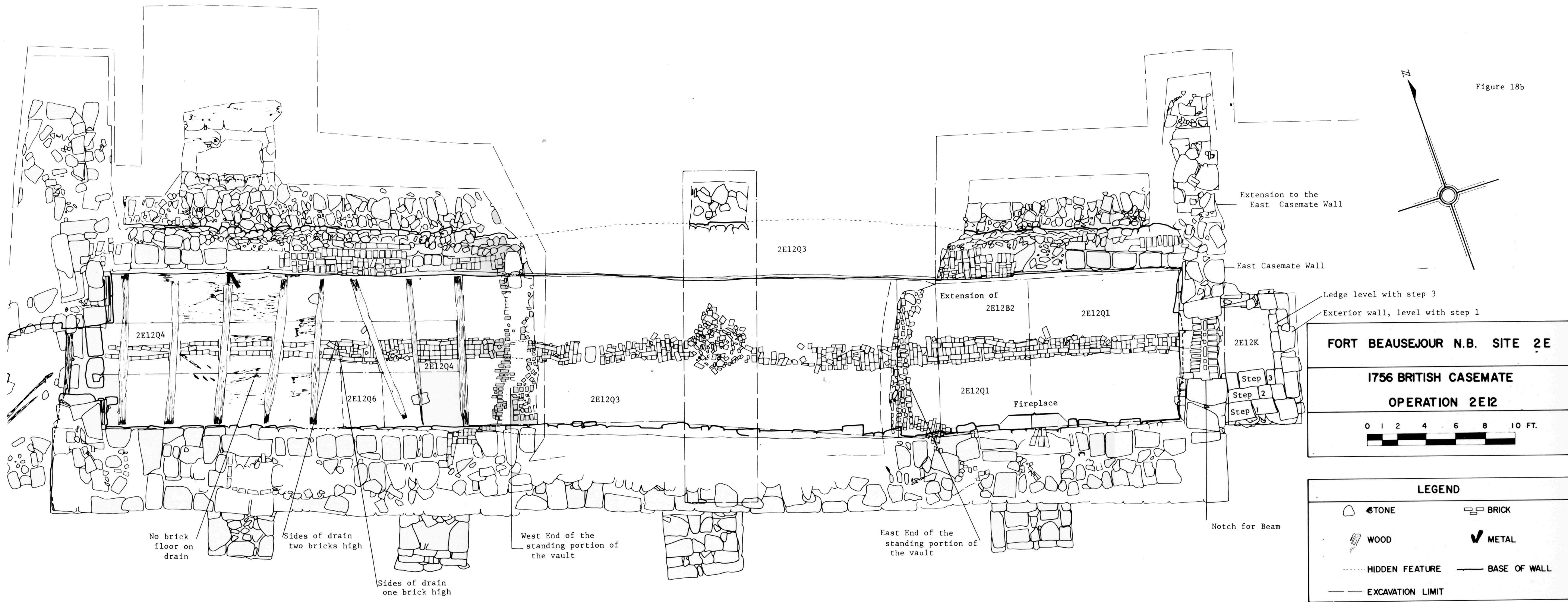
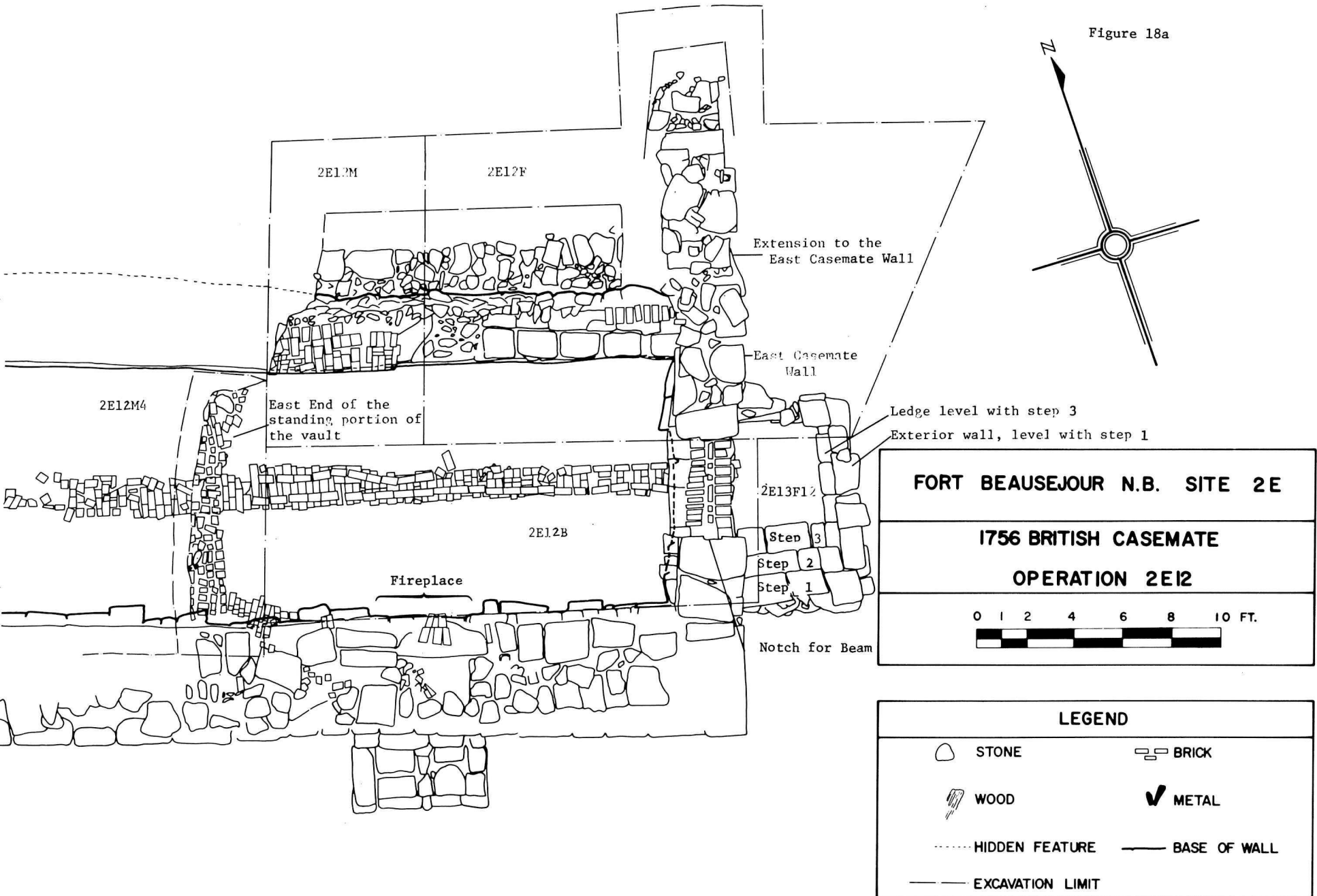
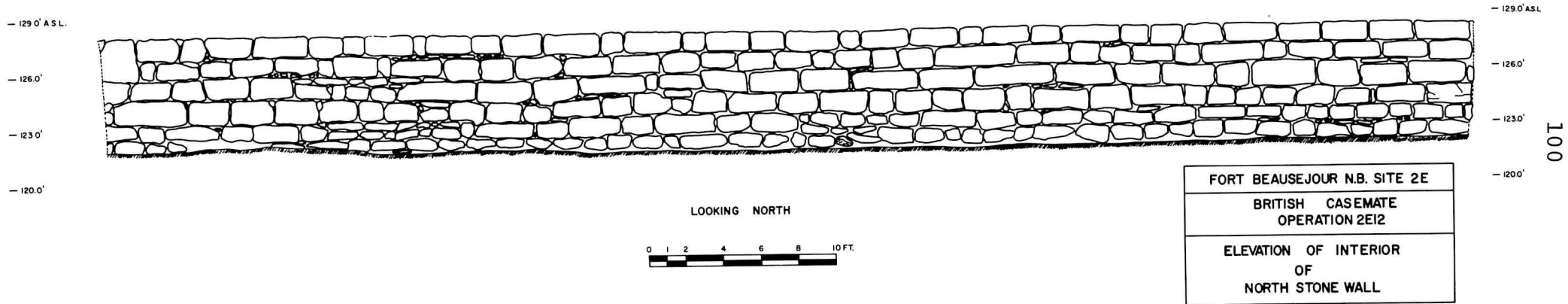
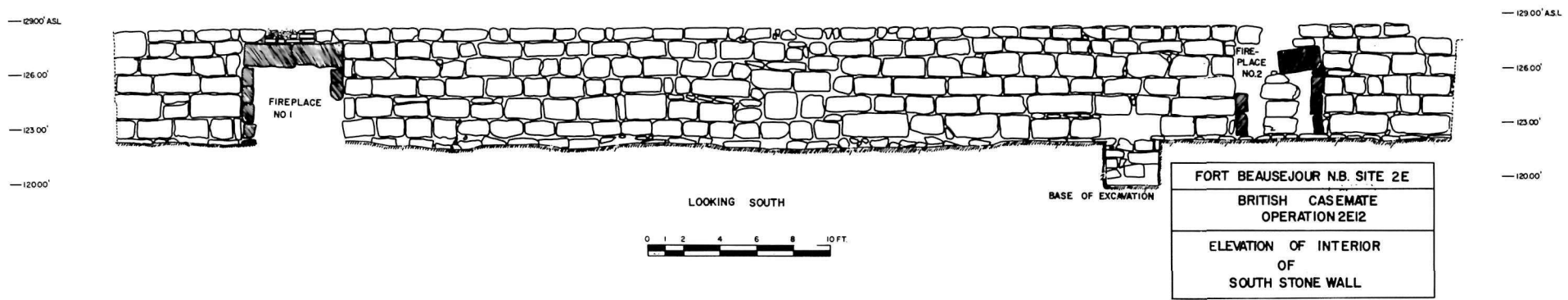

Figure 18a





19 North face elevation view (2E12). 2E-68-102-15



101

20 South face elevation view (2E12). 2E-68-102-20

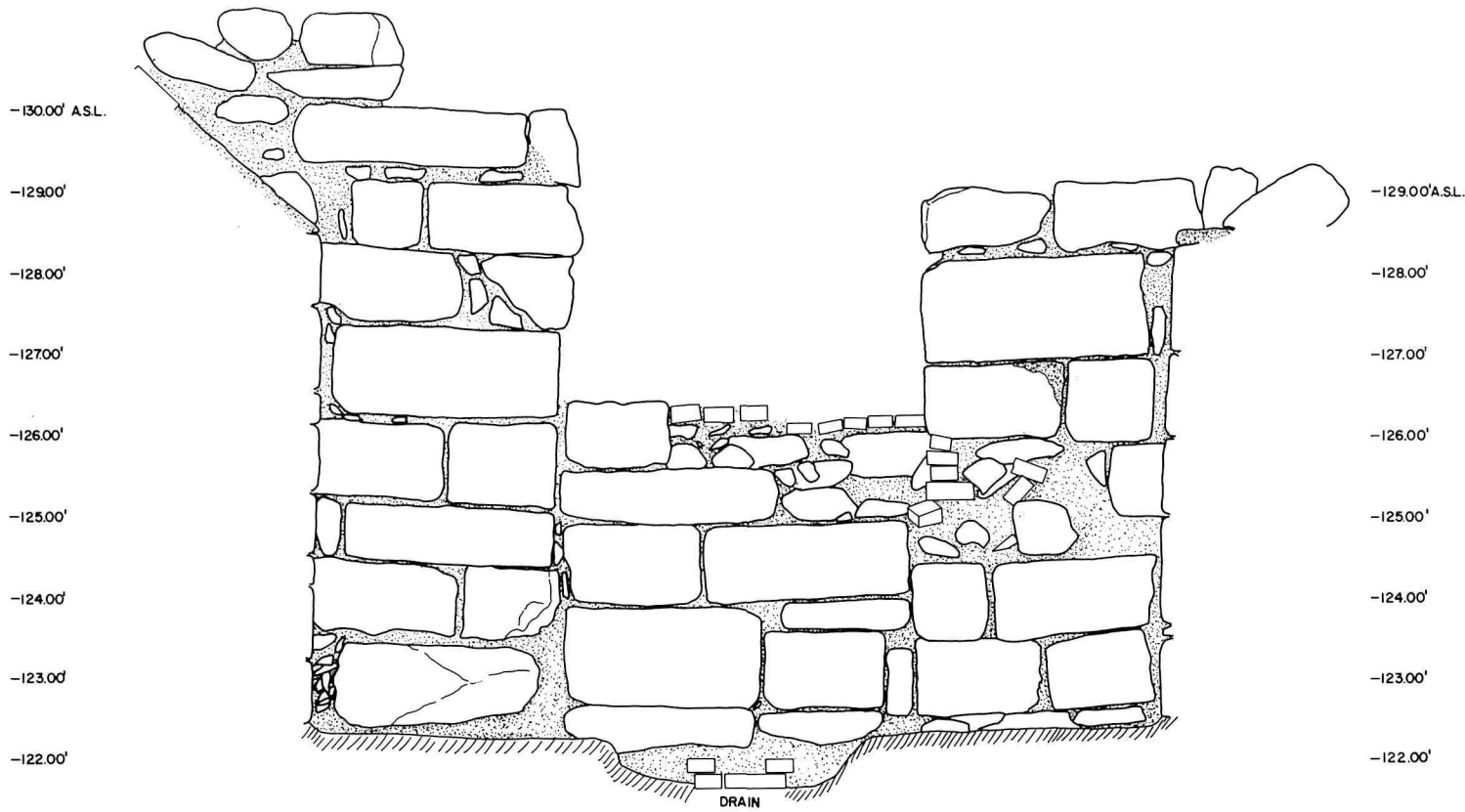

FORT BEAUSEJOUR N.B. SITE 2E
INTERIOR ELEVATION OF EAST WALL BRITISH CASEMATE OPERATION 2E12
0 1 2 FT

LEGEND	
STONE	MORTAR
BRICK	

102

01 East face elevation view (2E12), 2E-68-102-30

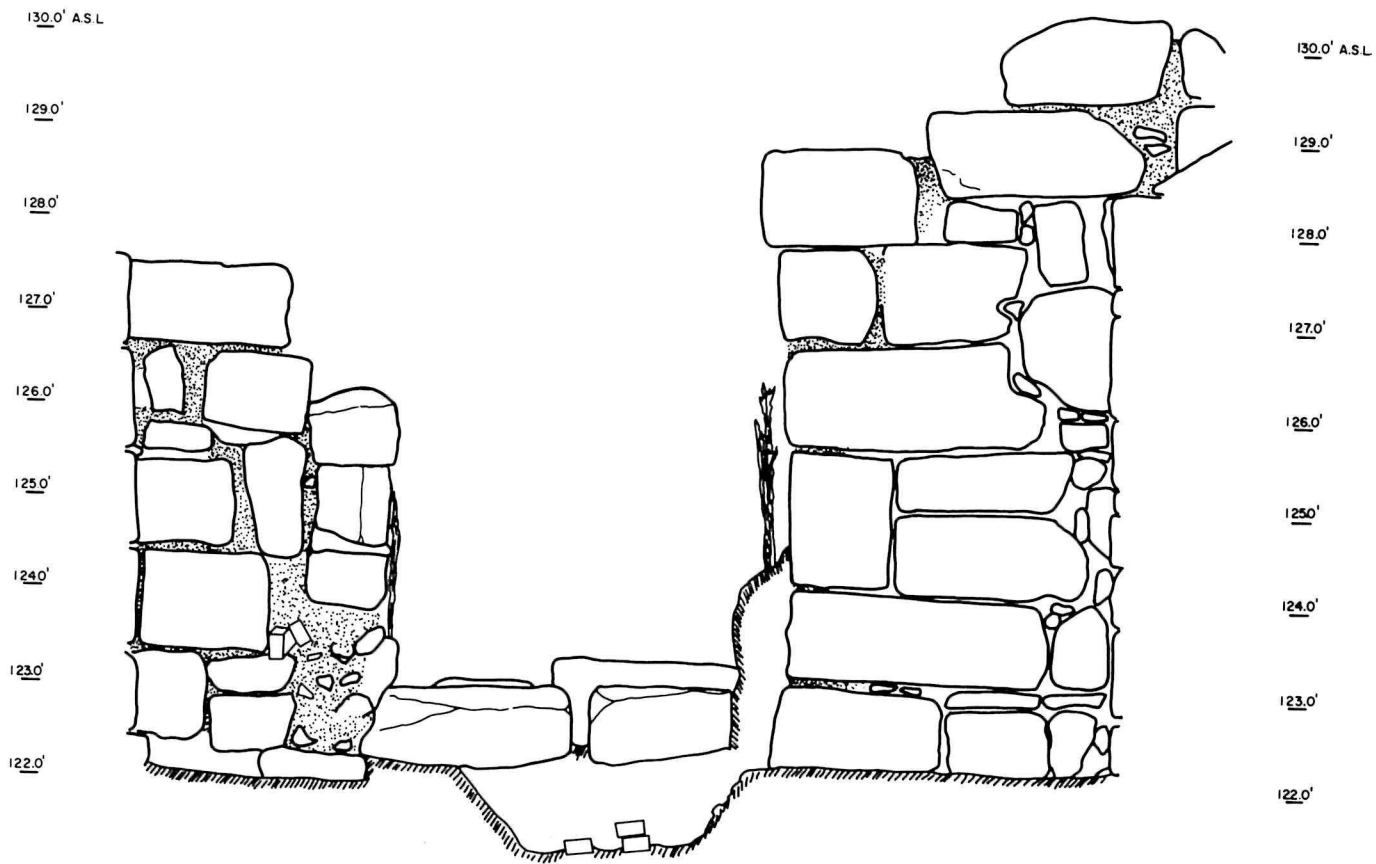

FORT BEAUSEJOUR N.B. SITE 2E
 INTERIOR ELEVATION OF WEST WALL
 BRITISH CASEMATE
 OPERATION 2E12

0 1 2 FT.

LEGEND	
	STONE
	MORTAR
	BRICK
	WOOD

103

22 West face elevation view (2E12). 2E-68-102-14



23 2E12Q6. Post excavation shot showing the open space in lower right corner of excavation which is the inlet of drain No. 1, and the difference in construction between the upper and lower parts of the south wall of the casemate. Camera facing south. 6 ft. scale aligned east-west (2E-2062 X).



24 2E12. General view of the east end of the British Casemate, showing the abutting below the window, the brick drain, the spring of the arch on the north and south walls. Camera facing east. No scale (2E-181 B).



25 2E12. General view of the east end of the British Casemate showing the abutting below the window and of the extension to the main east wall of the casemate and the bonding of the east wall to the south wall. Camera facing west. No scale (2E-180 B).

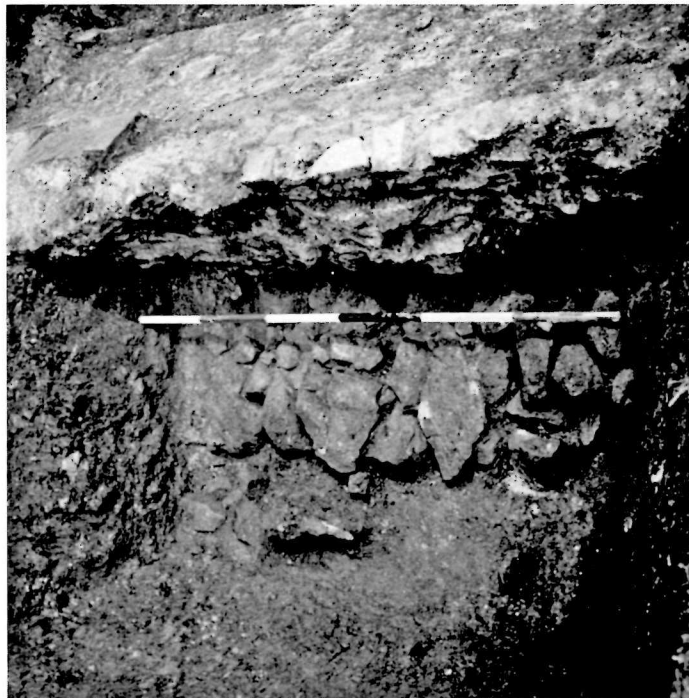

26 2E12F5. Post-excavation shot showing wall north of the north wall of the casemate. Camera facing down and east. 6 ft. scale aligned east-west (2E-1499 X).



27 2E12F21. Post-excavation shot showing the rubble found east of the casemate. Camera facing south. 6 ft. scale aligned east-west (2E1498 X).

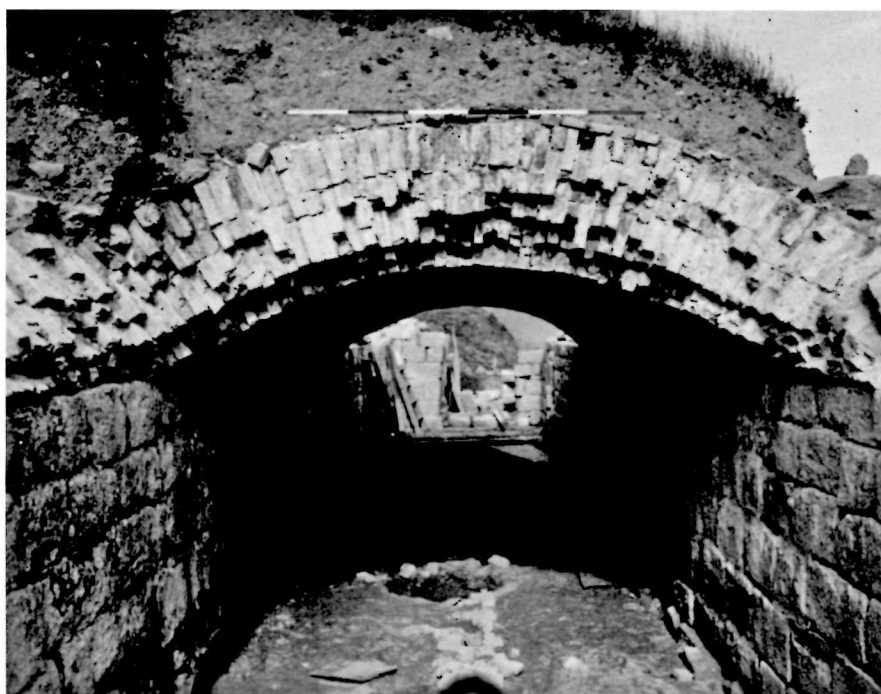

28 2E12. View of the east end of the casemate. Camera facing west. 6 ft. scale aligned north-south (2E-186 B).



29 2E12. View of the south half of the east end of the vault, showing rubble above arch. Camera facing west. 6 ft. scale aligned north-south (2E-184 B).

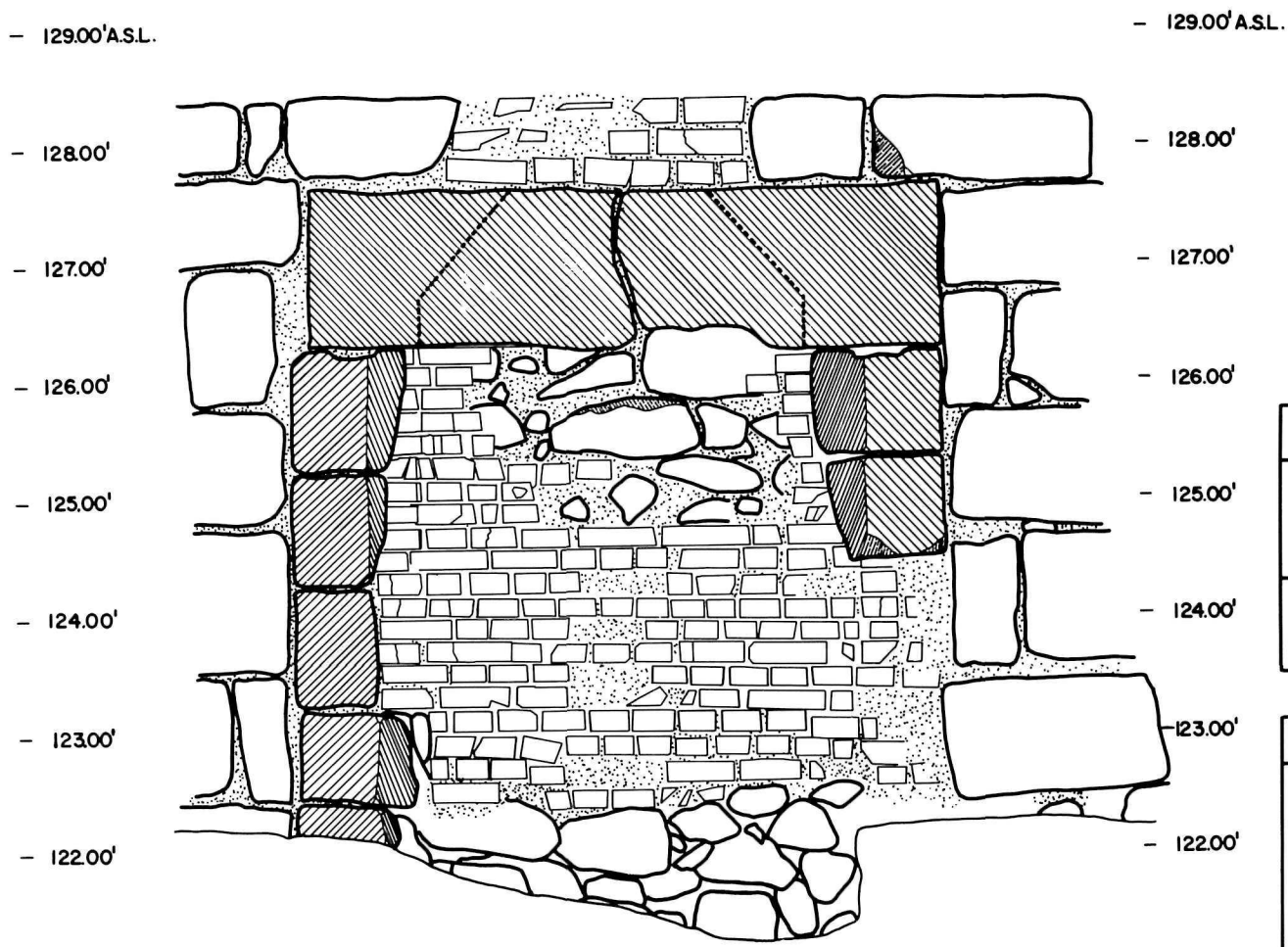

FORT BEAUSEJOUR N.B. SITE 2E
 ELEVATION OF EAST FIREPLACE
 BRITISH CASEMATE
 OPERATION 2E12

0 2 FT.

LEGEND	
STONE	SHAPED STONE
BRICKS	MORTAR
HIDDEN FEATURE	CUT STONE

108

30 Elevation drawing of fireplace at east end of casemate, operation 2E12. 2E-68-102-28

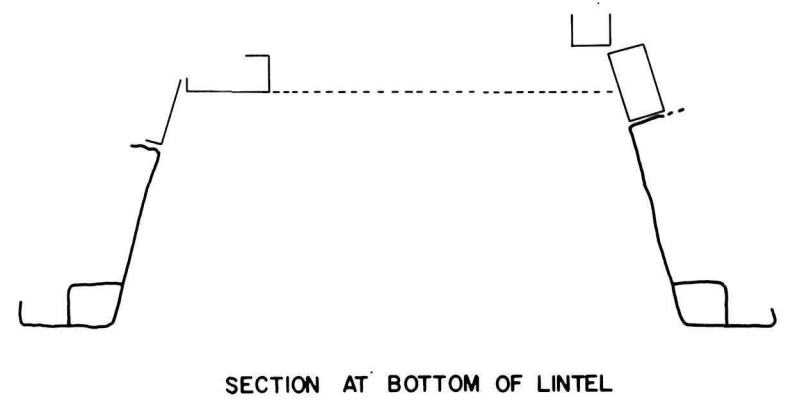
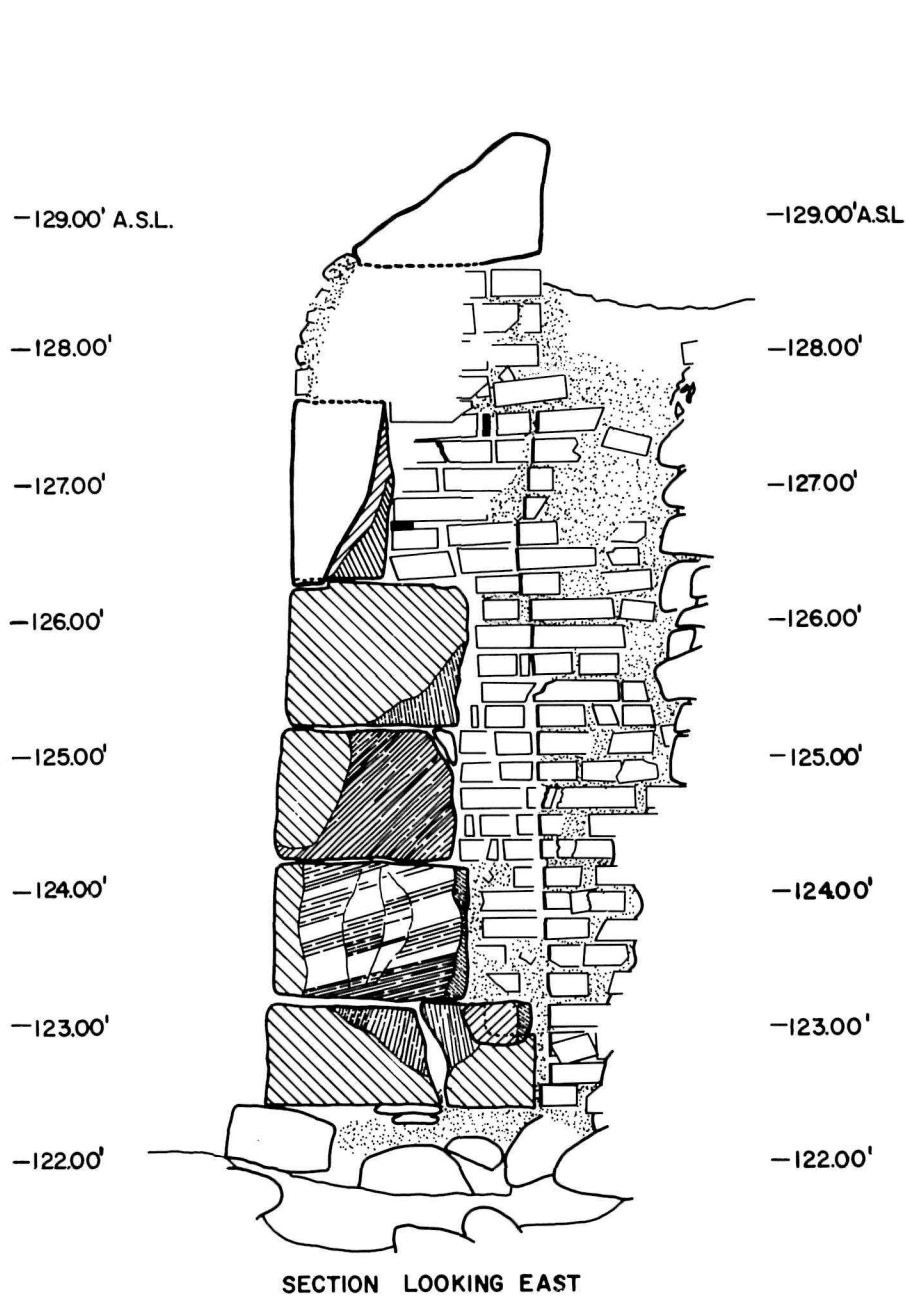

FORT BEAUSEJOUR N.B. SITE 2 E
SECTIONS OF EAST FIREPLACE BRITISH CASEMATE OPERATION 2E12

LEGEND	
STONE	SHAPED STONE
BRICK	MORTAR
HIDDEN FEATURE	CUT STONE
IRON	STONE IN X-S

109

31 Horizontal and vertical views of fireplace at east end of 2E12. 2E-68-102-29

FIGURE 32

The Lintel of the East Fireplace
in the British Casemate 2E12

Looking South

Not to Scale

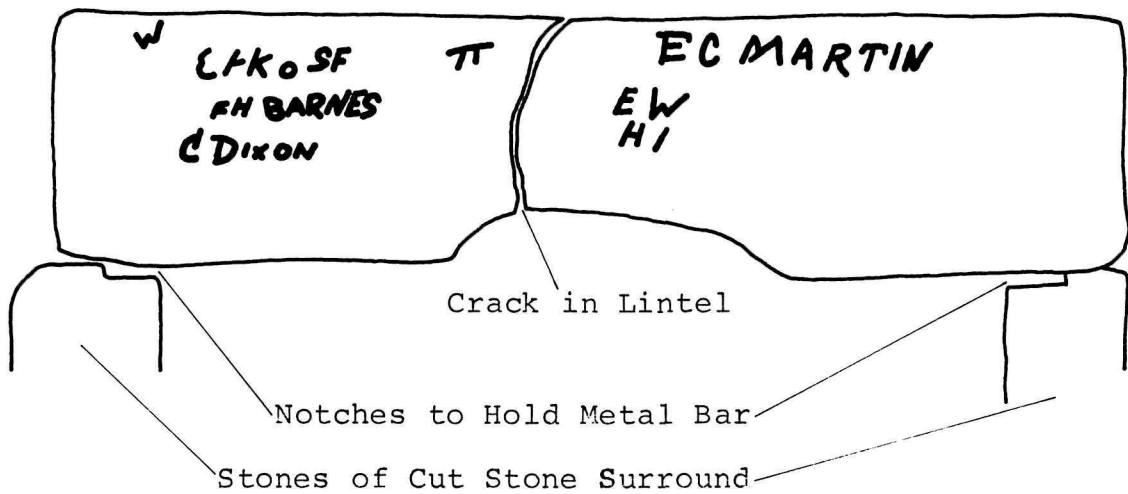



33 2E12. View of the back wall of the fireplace at the east end of the casemate, showing brick wall and rubble wall. Camera facing south. 1 ft. scale vertical (2E-3152 X).



34 2E1?. View of the east fireplace in the casemate showing the top of firebox and metal braces. Camera facing up. No scale (2E-3154 X).



35 2E12K6. Post-excavation shot. Camera facing south. 6 ft. scale aligned north-south (2E-1966 X).



36 2E12K6. Post-excavation shot. Camera facing north. 6 ft. scale aligned north-south (2E-1967 X).



37 2E12. General view of the west end of the British Casemate, showing the brick drain and the floor structure. Camera facing west (2E-179 B).

FIGURE 38

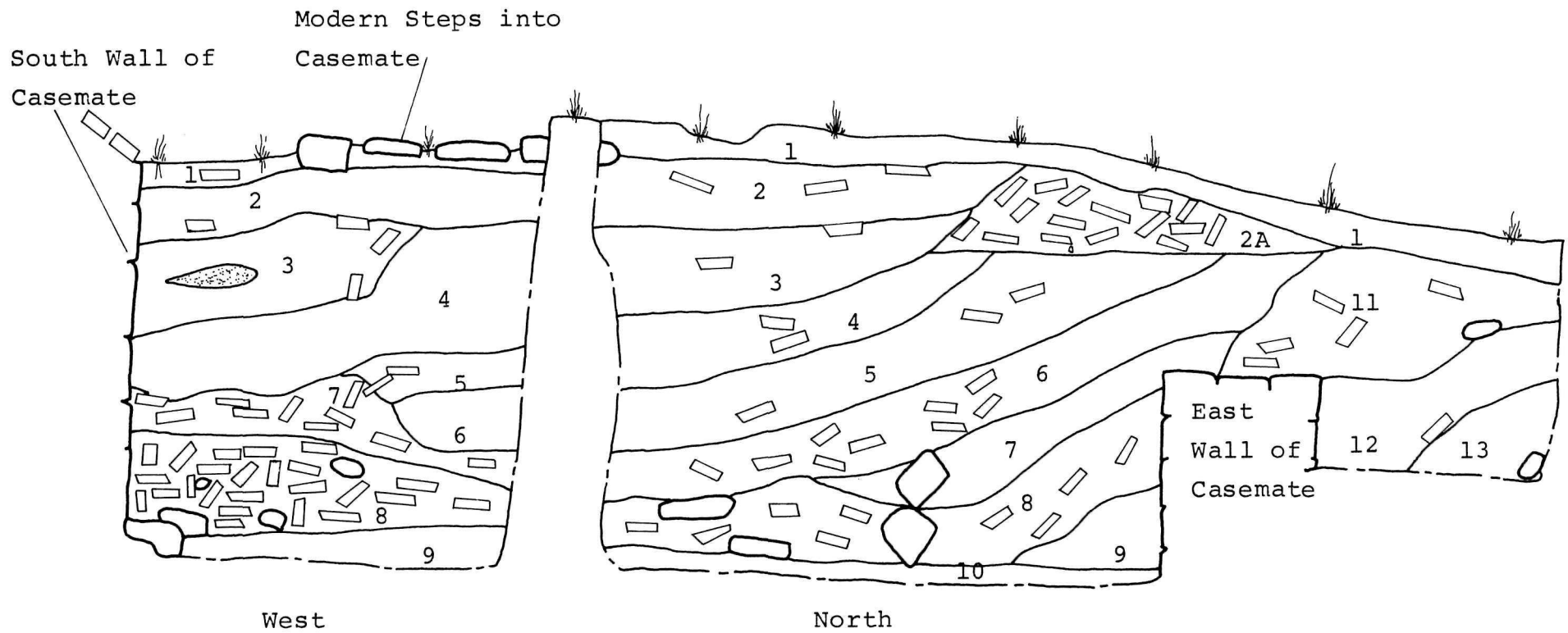

Soil Stratigraphy Layers of the West and North
Faces of 2E12B

39 2E20 plan showing location of sub-
operation 2E20R. (2E-67-102-13)

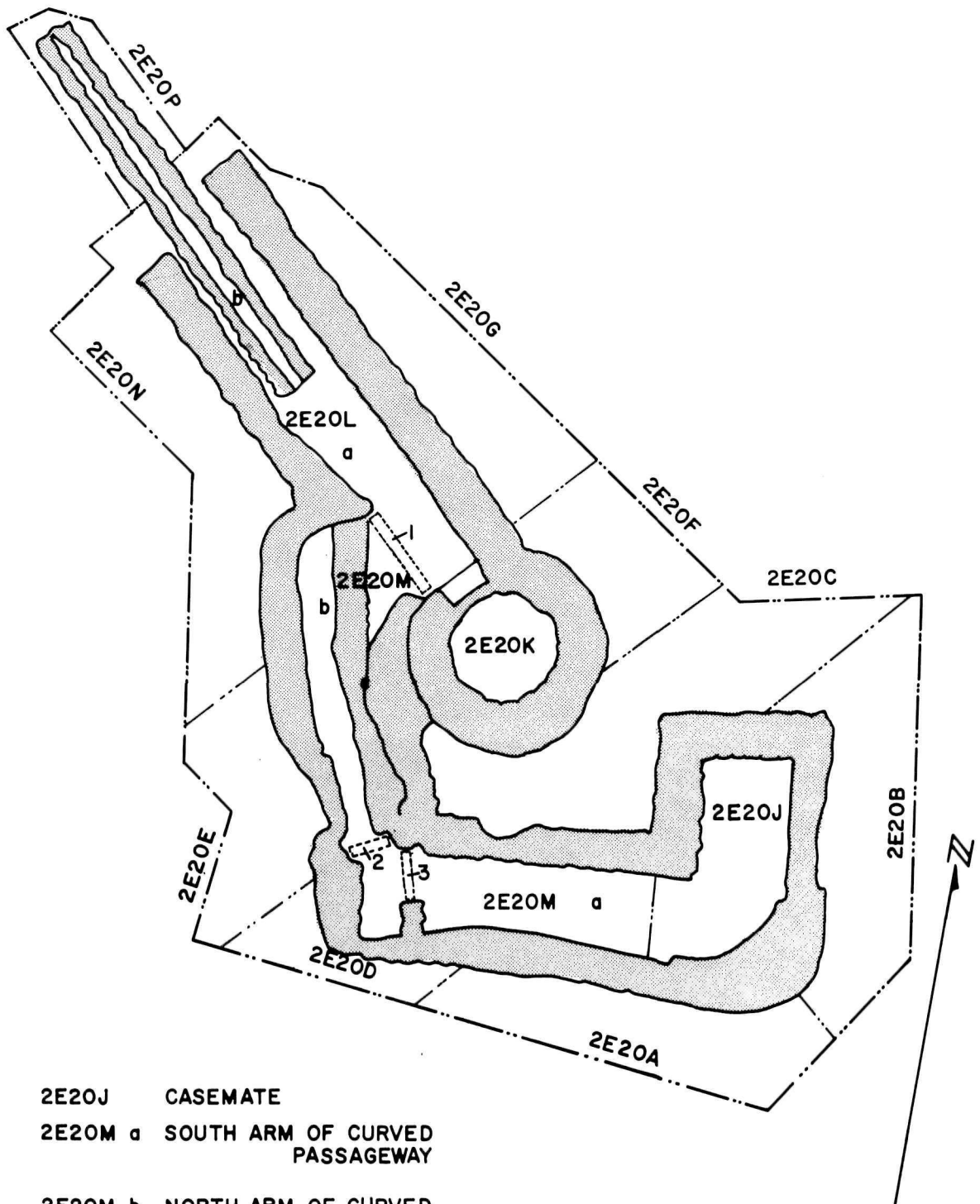

- 2E20J CASEMATE
- 2E20M a SOUTH ARM OF CURVED PASSAGEWAY
- 2E20M b NORTH ARM OF CURVED PASSAGEWAY
- 2E20M c DRAIN
- 2E20K WELL
- 2E20L a STRAIGHT PASSAGEWAY
- 2E20P b DRAINWAY
- 1,2,3 DOOR SILLS

Figure 39

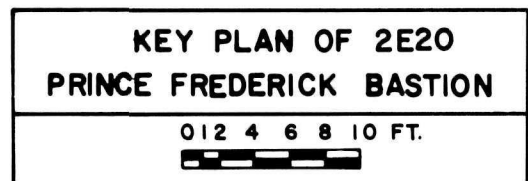



40 2E20R1. Post-excavation shot showing the east side of the west wall of 2E20J. Camera facing east. 2 ft. scale aligned north-south (2E-3224 X).



41 2E20R1. Post-excavation shot showing the south side of the north wall of 2E20M. Camera facing south. 2 ft. scale aligned east-west (2E-3226 X).

1970 Archaeological Excavations at
Fort Beausejour
by William Dendy

1970 Archaeological Excavations at Fort Beausejour
by William Dendy

vi	Preface
1	Drains
1	Introduction
6	Drain 3
6	General description
7	Notches and crossbraces
8	The lids of the drain sections
9	The connection between Drain 3 and Drain 5
9	The connection between Drain 1 and Drain 3
10	The planking of Drain 3
11	The nails used in Drain 3
12	Auxiliary features
13	Drain 5
14	Drain 5 - Lot 2E16Z4
15	Drain 5 - Lot 2E16Z8
16	Stratigraphy
17	Interpretation and conclusion
17	The wooden drain from the 2E22L powder magazine
20	The stone drain in 2E16S
20	Description of features
22	Stratigraphy
24	Interpretation and conclusion
26	The beams found in operation 2E26
27	Description of features
28	The beam in lot 2E26W1
30	Levelling blocks
31	Dowels

31	The post found in lot 2E27A23
32	The two beams in lot 2E26X1-2
34	Levelling blocks
34	Other wood fragments
35	The stone bracing walls
36	Stratigraphy
36	Interpretation and conclusions
39	Excavations in operation 2E27
40	Description of features
40	The wall found in lot 2E27A3 - Wall A
40	The wall found in lots 2E27A16 and 2E27A17 - Wall B
41	The rubble area between the walls found in lots 2E27A16 - 2E27A17 (Wall B) and in lot 2E27A3 (Wall A)
42	The wall found in lot 2E27A21 - Wall D
43	The wall found in lot 2E27A42 - Wall E
44	The north wall of the 2E22L powder magazine
44	Stratigraphy
45	Interpretation and conclusions

Tables

49	1	The slope of Drain 3
49	2	Co-relation of the stratigraphic soil layers of figures 4, 5 and 6
50	3	Co-relation of the stratigraphic soil layers of figures 16, 17 and 18

51 References Cited

Illustrations

53	1	Key plan showing the location of operations 2E16, 2E22, 2E23, 2E26, 2E27
54	2	Key plan showing 2E16, 2E27 and drain No. 3 and No. 5.
55	3	Plan of Drain 3, sub-operation 2E23C

- 56 4 The wooden drain
- 57 5 Plan of stone drain
- 58 6 The north face of sub-operation 2E16S, profile
- 59 7 The west face of lot 2E16Z13, profile
- 60 8 The south face of lot 2E16S19, profile
- 61 9 The stone drain
- 62 10 The stone drain
- 63 11 The stone drain
- 64 12 The stone drain
- 65 13 Artifact 2E27A23-15
- 66 14 The two beams and stone bracing walls in operation
2E26
- 67 15 The two beams in 2E26
- 68 16 Plan of sub-operation 2E27A
- 69 17 The north face of sub-operation 2E27A, profile
- 70 18 The east face of lots 2E27A3, 2E27A9, 2E27A11, 2E27A17,
2E27A26, 2E27A28, profile
- 71 19 The west face of lots 2E27A9, 2E27A11, 2E27A16, 2E27A28,
profile
- 72 20 The wall located in lot 2E27A3
- 73 21 The wall located in lot 2E27A16, 2E27A17
- 74 22 The wall located in lot 2E27A22
- 75 23 The wall located in lot 2E27A24

Preface

From 26 June 1970 to 28 August 1970 I conducted archaeological excavations at Fort Beausejour National Historic Park, Aulac, New Brunswick, under the direction of J. D. Swannack, Senior Archaeologist of the Research Division, National Historic Sites Service, Department of Indian Affairs and Northern Development, Ottawa, Ontario.

The excavations and detailed recording were undertaken as part of the restoration work at the fort. This work involved the installation of a modern drainage system around the perimeter of the parade square. Stabilization and reconstruction was also done on the structures in Prince William Bastion and Prince Frederick Bastion.

The sub-surface drainage at Fort Beausejour was originally investigated in 1968 by Zeller (Zeller 1968). At this time a modern drainage system was temporarily installed at a level slightly above the wooden drainage system. During the reconstruction work carried on in 1970 a permanent drainage system was installed around the perimeter of the parade square. This drain was laid at a level considerably lower than that of the wooden drainage system, necessitating excavation and removal of those sections of the wooden drain remaining *in situ*. Drain 1 along the northwest side of the parade square was in very poor condition when excavated in 1968, and was removed during the construction of the first modern drainage system.

The drainage outlet from the 2E22L powder magazine in Prince William Bastion was exposed during the restoration work.

A small amount of excavation was carried out in the well

in Prince Frederick Bastion and is not of significance to warrant inclusion in the following report. Information concerning this may be found in the 1970 field notes.

Excavations were also carried out along the south side of the parade square, between Prince William Bastion and Prince Frederick Bastion. The excavations in suboperation 2E16S, lots 2E16S6 to 2E16S24, and in lot 2E16Z5 located portions of a stone drain running toward the centre of the parade square, which may have been associated with the drainage of the casemate in Prince Frederick Bastion.

The section of the excavations parallel to the curtain wall and south of the British gate were designated as sub-operation 2E27A. The extent of these excavations was not great enough to determine the exact nature of the features found. However, they seem to form part of the second guard house built by the British in 1756, and a previously unrecorded sally port leading toward the British entrance.

In the course of the engineering work associated with the stabilization of the structures of the British entrance (2E26), three wooden beams were found below the gate structures. These seem to have been the sleeper beams of a casemate within the curtain wall, which would date from the French occupation of the fort.

Drains

Introduction

There were four main occupation periods in the history of Fort Beausejour: 1751-1755 French; 1755-1768 British I; 1776-1793 British II; and 1809-1833 British III (Herst and Swannack 1970: 1). Associated with each of these periods was a period of extensive construction in the area of the fort. There is little documentary evidence concerning the drainage systems. However, because of their association with structures of French origin the stone drains seem to have been built during the French occupation. Similarly, the wooden drains seem to have been built during the three periods of British occupation.

The drainage system was not laid out at one time, but was added to and redesigned during the three main British occupation periods as new buildings were constructed, as old buildings deteriorated or changed in function, and as the drain itself deteriorated.

When the curtain wall between Prince Henry Bastion and Prince Edward Bastion was rebuilt in 1755 to include a brick-vaulted stone casemate (2E12), it would have been necessary to provide for the drainage of any ground water which might percolate through from the ditch into the casemate. Accordingly, when the south wall of the casemate was being built, a channel was built through the wall (Dendy 1968: 66-67). A wooden box-like drain was then probably laid running south toward the stone curtain wall. It is quite possible that all evidence for this early drain has now disappeared. It is also possible that the sections one through four of drain 1 are the remains of this drain since they are quite differ-

ent in manner of construction when compared with sections five and six of drain 1.

During the second British occupation. 1776-1779, a large officer's barracks (2E19) was constructed on the north side of the parade square, backing against the south wall of the 2E12 casemate. The construction of the basement of this building would have interrupted the drainage from the casemate and quite likely destroyed the sections of the drain in this area. Since the problems of ground water from the ditch would have been increased by this basement, a new wooden drain, drain 2, was built at the west end of the building, adjacent to the interior west wall of the barracks (2E19). This drain must have flowed south along the line of the first drain from the casemate. It is possible that the whole drain was rebuilt at this time and that sections one through four of drain 1 were actually built as part of drain 2 (Zeller 1968:14). This interpretation of sections one through four, based on a similarity of design is preferable to considering them to be part of the original drain out of the casemate. When the original drain through the opening of the exterior south wall of 2E12 was disrupted by the construction of the officer's barracks during the second British occupation, it was necessary to provide an alternative mode of drainage for the interior of the casemate. Accordingly, a brick drain (2E12Q) was constructed running east-west along the length of the casemate, overlain by the sleeper beams and planking of the floor structures of the interior of the casemate. The drain flowed from the east entrance to a sump half-way along the length of the casemate. From the sump the drain flowed west to the west entrance of the casemate to connect with a wooden drain, drain 6, outside the casemate (Dendy 1968: 64-66).

Drain 6 was narrower than the other wooden drains excavated at Fort Beausejour (Zeller 1968: 26-28). Although it did not have a bottom board, it seems to have flowed southeast, away from the entrance to the casemate, towards the northeast corner of the 2E17 barracks. The line of drain 6 cut off the end of the stone drain leading out of the French built wooden powder magazine in Prince Edward Bastion (2E11). The magazine was abandoned *ca.* 1760 (Herst and Swannack 1970: 8), but it is probable that the stone drain continued to function for a considerable period after this date since it was not destroyed or dismantled and thus could still drain water accumulated in the area. The stone drain was removed south of the line of drain 6. The direction of flow of drain 6 and its relation to the 2E17 barracks is not clear. However, it is possible that drain 6 was linked with a now destroyed drainage system along the exterior side of the earlier structure in 2E17.

On the basis of its similar manner of construction, it seems probable that drain 4 was built at the same time as drain 2, during the second British occupation. Drain 4 ran southeast from the southeast corner of the 2E17 barracks and then turned south on a continuation of the line of drain 1. As excavated, drain 4 sloped slightly toward the 2E17 barracks (Zeller 1968: 22), but as this seems functionally unlikely, this slope may be due to the very disturbed and decayed condition of the drain. Drain 4 may have connected with the hypothetical drain along the east wall of 2E17. It probably also connected with the south end of drain 2 and flowed south to the drainage under the British stone curtain wall between Duke of Cumberland and Prince William Bastions (Herst and Swannack 1970: 14, 15).

When Fort Beausejour was re-occupied shortly before

the War of 1812, it was in a very dilapidated condition. During the third period of British occupation, both the 2E16 and the 2E17 barracks were enlarged. The rebuilding of 2E17 interrupted the drainage along the east side of the building through drains 4 and 6. Only the system in the area of drain 4 remained operative. The full system does not seem to have been rebuilt after 2E17 was completed. Since the 2E12 casemate was still being used a new system of drainage was necessary. The 2E19 barracks was no longer in use at this time and the north sections of drain 1 were rebuilt along the line of the original drain, diagonally across the width of the barracks, to connect the channel in the south wall of the casemate with the section of drain 1 running south toward the stone curtain wall. When the drainage system was excavated in 1968, both these sections were designated as drain 1. The north end of drain 2, running out of the west compound wall was not incorporated into this newer system. It was not removed, but having been cut through, it was probably not operative. Drain 4 was not rebuilt and it seems to have remained operative.

When the 2E16 officer's barracks was rebuilt it was necessary to make provision for drainage in this area. This was done by the building of drain 3 and drain 5. Drain 3 ran east-west across the north side of the parade square, from its inlet in room 4 of the 2E16 barracks (Dendy 1968: 19,20). The west end of the drain connected with drain 1 at the junction of the newly built section of drain 1 and the remaining section of drain 2. The level of drain 3 dropped 1.08 ft. between the inlet in 2E16 and the junction with drain 1, from 120.17 ft. above sea level to 119.09 ft. above sea level (Table 1).

During the building of the 2E16 barracks, drain 5 was laid along the exterior side of the west wall of the barracks. This drain sloped from the north and south ends toward the line of drain 3. At this point drain 5 was 0.8 ft. above drain 3, and they were connected through hole in the bottom of drain 5, a vertical wooden pipe and a hole in the lid of drain 3 (Zeller 1968: 26). At both ends drain 5 was either below or close to the stone drains leading out of Prince Henry Bastion and Prince Frederick Bastion.

Drains 3 and 5 and the new section of drain 1 were all built in a box-like form, with the bottom plank placed between the two side panels. Drains 2 and 4 were built in a box-like form, with the side panels standing on the bottom.

On the surface the new drainage system of the third British occupation was supplemented by brick splash drains around the rebuilt 2E16 and 2E17 barracks. The 2E16 splash drain flowed south toward the 1755 British entrance. The 2E17 splash drain flowed south toward the British stone curtain wall.

The efficiency of these wooden drainage systems is a matter of conjecture. Presumably, the systems would not have been renewed along the same lines in each of the British occupation periods if they had not proven at least partially successful. However, by the third period of occupation, the system must have been almost completely non-functioning. The rebuilding at this time would only have partially corrected the situation because the southern end of the circuit was not rebuilt.

Drain 3

Drain 3 ran along the northeast side of the parade square, parallel to the south wall of the 2E19 barracks. When found in 1968, it was in very good condition and was left undisturbed below the first modern drainage system. The drain was arranged in eight sections (not seven as in Zeller 1968), of which the seven westmost sections were excavated in 1968 (Zeller 1968: 16-21) (Fig. 3).

General Description

Drain 3 was built in a simple box form, with its entire length of 106.54 ft. (Zeller 1968: 16), being completed in eight sections consisting of lid, side panels and a bottom plank. The average depth of this box-like channel was 0.47 ft. It varied in depth from a maximum of 0.57 ft. at the west end of section six, to a minimum of 0.39 ft. at the west end of section three. In each section the bottom and side panels were almost equal in length. The planks forming the lids were generally placed so that they overlapped an adjacent section. The bottom plank was placed between the two side panels, so that the interior face of each of the side panels butted against one edge of the bottom plank. This joint was secured by a series of nails driven horizontally through the side panels into the edge of the bottom plank. The lower edges of the side panels were not necessarily flush with the lower face of the bottom plank.

The ends of each of the side panels and the bottom planks were bevelled to fit with those of the adjacent sections in a through-splayed scarf joint. None of these

joints were secured by pins or nails. The joints in the bottom of the drain were designed so that the west end of one plank over-lapped the east end of the next. This form and arrangement of joint was necessary to keep the planking from being forced apart by the normal east to west flow of water in the drain. The width of the bevel of these joints varied from 0.3 ft. to 0.4 ft. wide. The joints in the side panels were arranged so that the west end of a panel formed the interior side of the joint and the east end of the adjacent panel, the exterior side. This position was also necessary to keep the normal east to west flow of water from forcing the planks apart.

The Notches and Crossbraces

The side panels of the drain were braced with wooden crossbraces to prevent the inward collapse of the sides (Herst and Swannack 1970: 33). There were no crossbraces in drains 2, 4, 5 or 6. However, similar crossbraces were found in sections five and six of drain 1. They were not found in sections one through four of drain 1. There were 16 crossbraces in drain 3, two in each section, spaced on the average 7.46 ft. apart. The spacing varied from a maximum of 9.4 ft. to a minimum of 5.62 ft. These crossbraces varied between 1.01 ft. and 1.03 ft. long, and averaged 0.23 ft. wide horizontally, varying from a maximum of 0.27 ft. to a minimum of 0.17 ft. They averaged 0.12 ft. thick vertically, varying from a maximum of 0.14 ft. to a minimum of 0.09 ft. These crossbraces were dove-tailed into notches cut in the upper edges of the side panels. Accordingly one side of each crossbrace was notched so that it would be held more securely in place (Zeller 1968:

Fig. 6d).

Twenty-nine notches were recorded when drain 3 was dismantled. Of these, two are in the eastern part of section seven (cat. no. 2E23C26-2). The two notches at the east end of section one disappeared when the section was removed in 1968. The western notch in the south side panel of section eight was too poorly preserved to be recorded accurately. The notches averaged 0.22 ft. wide, which is slightly narrower than the horizontal width of the crosspieces. This may have been intentional to assure a tight fit. There are pressure marks on several of the crossbraces from contact with the sides of the notch. The crossbraces were not held in place by nails or pins.

The Lids of the Drain Sections

Eight planks were placed over the drain as a cover. The planks were bevelled on each end and laid with through-splayed scarf joints. The planks covered the channel and usually extended slightly over the exterior faces of one or both of the side panels. The lids were held in place by four nails, one near each end of each of the side panels. The scarf joints were not nailed or pinned. The lids of sections one, two and three all overlapped the section to the east. The lid of section four was considerably shorter than the side panels of section four. Therefore the lid of section five overlapped the east end of section four. The lids of sections six and seven each overlapped the east end of the adjacent section. The lid of section eight covered only the complete length of section eight.

The Connection Between Drains 3 and 5

The point of intersection with drain 3 was excavated and it was discovered that drain 5 crossed over drain 3, about 0.8 ft. above it. The two were connected, however.

Unfortunately, drain 5 had disintegrated almost completely in this region, . . . There were also the remains of a wooden pipe connecting the two drains. It was made of a number of vertical pieces of wood forming a rough circle, measuring 0.45 ft. E-W and 0.3 ft. N-S. There were two nails lying across the opening, perhaps acting as a grate, or they may have helped to hold it together (Zeller 1968:25).

The vertical wooden pipe mentioned above connected with a rectangular hole in the lid of section eight. It was 0.82 ft. long east-west on the north side; 0.8 ft. long east-west on the south side; and 0.47 ft. east-west on the east side; and 0.44 ft. east-west on the west side. The north side averaged 0.29 ft. from the north edge of the lid; the south side, 0.35 ft. from the south edge. The west side averaged 8.4 ft. from the west end of the lid; and the east side, 3.57 ft. from the east end.

The Connection Between Drain 1 and Drain 3

The west end of section one of drain 3 connected with drain 1 between sections four and five of drain 1 (Zeller 1968: Fig. 2). The angle between drains 1 and 3 was about 60 degrees, and to facilitate the butting of the two drains the exterior faces of the west ends of the panels of section one of drain 3 were bevelled. The side panels of section five of drain 1 were also bevelled in a similar manner (Zeller 1968: Figs. 4a, 4b). This allowed the two drains to be joined by through-splayed scarf joints in a manner similar to that used to join the individual sections of drain 3. These joints were not pinned or nailed. Drain 3 flowed into drain 1, but drain 1 was not continuous across the junction. Rather section five

of drain 1 stopped at the north side of drain 3 and section four began at the south side of drain 3. No wood structure spanned the gap, either as a lid, side panel or bottom. This must have considerably decreased the efficiency of the drain.

The Planking of Drain 3

The planking in drain 3 was probably spruce as this wood was quite common in the fort and in the surrounding area. The longest piece of planking found was the lid of section three which was 15.8 ft. long. The average length of the planking was 12.55 ft. The widest plank in the drain was also the lid of section three, which was 1.27 ft. wide at the west end. The average width of the planking in drain 3 was 0.94 ft. The thickest plank found in the drain was the south side panel of section one, which was 0.2 ft. thick. The average thickness of the planking in drain 3 was 0.15 ft.

The Nails used in Drain 3

As stated above, the side and lid of the sections of the drain were held in place by iron nails, which were probably hand-forged. When the drain was dismantled, 120 nails were recovered. The lids of sections two through eight were each held in place by four nails, two near each edge. These nails were driven vertically into the upper edge of the side panels. No recognizable nails or nail holes were found in the lid of section one, and it is not impossible that nails were not used to hold the lid of this section in place. The spacing of these nails, in relation to each other and in relation to the ends of the lid, was dependent on the total length of the plank and followed no consistent pattern. However, in most cases, the spacing of the nails on the north side of

the lid was very close to that of the nails on the south side of the lid. The lids of sections two through eight were each secured to the side panels of the same section, rather than to the side panels of an adjacent section, even though each lid usually overlapped the side panels of an adjacent section.

Approximately 50 nails were used to fix the north side panel to the north edge of the bottom. Forty-seven of these were located during the 1970 excavations. It is quite likely that there were two or three more nails in those parts of sections one and seven which were removed in 1968. The average interval between the nails on the north side of the was 2.34 ft.; however, the spacing varied from a maximum of 5.2 ft. to a minimum of 0.65 ft. The average spacing of the nails up from the lower edge of the side panel was 0.09 ft. But here again the range of variation was quite large, the maximum spacing being 0.12 ft., and the minimum 0.06 ft.

Approximately 55 nails were used to fix the south side panels to the bottom of the drain; 52 of these nails were located during the 1970 excavations. It is quite possible that there were two or three more nails in those parts of sections one and seven that were removed in 1968. The average interval between the nails was 2.07 ft., varying from a maximum of 3 ft. to a minimum of 0.4 ft. The average spacing of the nails on the south side up from the lower edge of the side panel was 0.09 ft., but on this side the range of variation was much greater than it was on the north side of the drain, the maximum spacing being 0.15 ft. and the minimum, 0.04 ft.

Of the nails located in the 1970 excavations, 59 were actually removed from the wooden panels. Most of the nails measured 0.02 ft. by 0.02 ft. in cross-section. However two

different nails were found in section one, one of which was 0.02 ft. by 0.03 ft. in cross-section; and the other, 0.03 ft. by 0.03 ft. in cross-section. Five of the nails which were removed were complete, with sharp points. The longest of these was 0.42 ft. long. Most of the other nails removed had slightly blunted points. These points were probably intentionally blunted to avoid splitting the wood used in the drain.

Auxiliary Features

During the building of the drain, it was necessary to adjust the slope of the individual sections. The levels of sections one through five and section eight were adjusted by the placing of wood fragments, that were probably building scraps, under the drain box. These scraps varied considerably in dimension, as would be expected. In many cases the desired slope of the drain was obtained by the use of several pieces, piled one on top of the other. In section one the drain level was adjusted by the use of a medium-sized stone. No wood scraps were found below sections five, six and seven.

A thin layer of fine clay was found directly below section one of the drain. Below this was a layer of fine to medium-sized gravel, about 0.1 ft. thick.

Drain 5

Three sections of drain 5, 22.8 ft. long, were located in the 1970 excavations. These sections were very poorly preserved but it was apparent that the drain was built in the same box-form used elsewhere in the fort. The width of the drain, as shown by the section excavated in lot 2E16Z8, was approximately 0.5 ft. The depth of the channel could not

be determined because of the deterioration of the side panels. The two sections found in lot 2E16Z4 were badly crushed, the east side panel being folded beneath the lid. The elevation of the upper surface of the collapsed sections was 121.99 ft. above sea level at the south end and 121.47 ft. above sea level at the north end. Neither the lid nor the bottom of the drain section found in lot 2E16Z8 were preserved. The position of the side panels was indicated only by wood fibres adhering to the clay surrounding the drain. The elevation of the clay surface at the bottom of the drain dropped from 122.13 ft. above sea level, at the south end to 121.79 ft. above sea level at the north end.

In lot 2E26Z5 a section of stone drain was found below the level of the brick splash drain. This seems to have been related to the casemate in Prince Frederic Bastion (Operation 2E20).

Drain 5 - Lot 2E16Z4

The lid of the north section of the two found in lot 2E16Z4 was not preserved. The lid of the south section was 5.45 ft. long and 0.08 ft. thick as preserved. Only 0.28 ft. of the original width of the lid was preserved. There were no nail holes in the lid.

The west side panel of the north section was 5.9 ft. long and averaged 0.12 ft. thick. The complete width of the side panel was not preserved. As preserved, it averaged 0.32 ft. in width. It was not possible to tell if there had been any nails in the upper edge of the side panel to secure the lid. The side panel was secured to the bottom by two nails in the lower edge of the panel. The west side panel of the south section of the drain found in this lot was 6.1 ft. long and 0.12 ft. thick. The width of the panel was not completely

preserved but the section excavated averaged 0.41 ft. in width. There was evidence that the lid had been secured to the side panel by at least one nail. The side panel had been fixed to the bottom of the drain by at least three nails.

There was one east side panel for both sections of the drain found in lot 2E16Z4. As preserved the panel was 11 ft. long and averaged 0.12 ft. thick. The width was not completely preserved, but as excavated the panel averaged 0.36 ft. wide. It was not possible to determine whether the lid had been nailed to this panel. The side panel had been fixed to the bottom by two nails through the panel, near the lower edge at the south end.

There was also one bottom panel for both sections. As preserved, this was 12 ft. long and averaged 0.14 ft. thick. The width of the bottom was not completely preserved, but as preserved it averaged 0.31 ft. wide. There were four evenly-spaced nail holes in the west edge of the bottom.

There were two levelling blocks located under the drain in lot 2E16Z4. The first, was under the joint in the top and west side panels between 3.4 ft. and 4.3 ft. from the south end of the bottom panel. It was 1.3 ft. long, 0.5 ft. wide and 0.06 ft. thick. The northern block was located between 5.6 ft. and 6.5 ft. from the south end of the panel. It was 1.25 ft. long, 0.5 ft. wide and 0.05 ft. thick.

Drain 5 - Lot 2E16Z8

Five nails were found *in situ* on the east of the drain and were evidently used to fix the bottom and east side panel together. The first was 1 ft. from the north end, 10.8 ft. from the south end, and 2.8 ft. from the adjacent nail. The second was 3.8 ft. from the north end of the panel, 8 ft. from the south end and 2.55 ft. from the adjacent nail. The third

nail was located 6.35 ft. from the north end, 5.45 ft. from the south end and 1.35 ft. from the adjacent nail. The fourth nail was located 7.7 ft. from the north end, 4.1 ft. from the south end and 1.75 ft. from the adjacent nail. The fifth nail was located 9.45 ft. from the north end and 2.35 ft. from the south end.

A vertical nail was found in the upper edge of the east side 1.4 ft. from the north end and 10.4 ft. from the south end. This nail probably was one of those fixing the lid to the east side panel.

Five nails were found *in situ* on the west side of the drain that would have served to fix the west side panel to the bottom. The first was 5 ft. from the north end, 6.8 ft. from the south end and 1.8 ft. from the adjacent nail. The second nail was 6.8 ft. from the north end, 5 ft. from the south end and 1.05 ft. from the adjacent nail. The third nail was 7.85 ft. from the north end of the drain, 3.95 ft. from the south end and 1.95 ft. from the adjacent nail. The fourth nail was 9.8 ft. from the north end and 2 ft. from the south end.

When the drain was laid, several small and medium sized stones were placed around it; though not in any consistent manner. These stones were probably intended to protect the drain from the weight of the covering soil.

Stratigraphy

The soil stratigraphy associated with drain 5 and with the exterior side of the west wall of the 2E16 Barracks, was somewhat confused due to the excavations of two previous seasons and the weathering during four years. However, some conclusions can be drawn. The stratigraphy (Fig. 7) does not show a foundation trench on the exterior side of the barrack's wall

and therefore it seems likely that the wall was backed into the sides of a pit the size required for the basement. It also does not indicate that drain 5 was built in a trench. The drain rests on a layer of sandy clay - 7.5 YR 4/4 Dark Brown (Layer 6; Fig. 7). Above this extends a layer of sandy clay, with small stones - 7.5 YR 4/4 Dark Brown (Layer 2; Fig. 8) which covers the drain and extends upwards to the sod layer. There is little difference between Layer 2 and Layer 6 and within Layer 2 there is no sign of a trench within which drain 5 could have been laid. This would indicate that the drain was laid during the construction of the 2E16 barracks and after the west wall had been partially built. This is quite feasible and is supported by the close connection between the east end of drain 3 and the wall structure. However, the absence of a foundation trench also implies that above the level of the drain the barracks were being built in a great pit which extended over seven feet beyond the walls. This seems most unlikely on the basis of the cost and inconvenience of such building methods in a fort as small in internal area as Fort Beausejour, and of the quality of the masonry of the exterior face of the foundation wall of the barracks which is much worse than would be expected had the upper part of the wall been built freestanding. This is also unlikely because of the existence of the stone drain originally found in lot 2E16Z5 which probably pre-dated the 2E16 barracks. Although these reasons do not rule out such building methods, over at least part of the area, it is more satisfactory to assume that the drain was built in a trench which could also have been used during the building of the wall and that the traces of this trench have completely disappeared. The stratigraphy has been similarly affected in other areas of Fort Beausejour, notably in the area of the French casemate in the curtain wall between Prince Frederick and Prince William Bastions.

The stratigraphy of Figure 8, the west face of lot 2E16Z13, is more closely associated with the stone drain structure originally located in lot 2E16Z5 and will be discussed below.

Interpretations and Conclusions

Drain 5 was a simple wooden box drain covered with a wooden lid, very similar to drain 3. It does not seem to have been as elaborately built with cross braces and it is not as well preserved. It was built later than drain 3, since it is above the drain and the slope of the south half of the drain is south to north flowing into drain 3. However, the interval between the building of drains 3 and 5 was probably not very long, since drain 5 is clearly associated with the building of the upper section of the west wall of the 2E16 barracks. The exact manner in which the drain was built is not clear from the stratigraphy. But it seems quite likely that it was built in a trench extending about two feet west of the exterior face of the west wall. This existence of the narrow trench is supported by the preservation of the stone drain structure found in lot 2E16Z5 which would have been destroyed had a wider trench been dug.

The Wooden Drain from the 2E22L Powder Magazine

During the 1970 season, excavations were conducted in the area of the 2E22L powder magazine to investigate a section of wooden drain that was located during the reconstruction work in the area.

Operation 2E22 was originally excavated in 1968 by Moussette (1969:45-57). An arbitrary north direction was established at this time that is approximately parallel with the curtain wall between Prince William Bastion and Prince Frederick Bastion.

During stabilization the west interior wall of the 2E22L powder magazine was dismantled. When the fill had been partially removed from behind the wall a section of wooden drain was located (Fig.4). This drain connected with the drainage channel through the west wall at the northwest corner of the magazine (Moussette 1969:50-51, Fig. 37) and ran approximately southwest-southeast.

The drain channel was preserved in two sections. The first section was formed by the stones of the north and west walls of the magazine, and ran east-west parallel to the north wall of the magazine. This channel was 3.1 ft. long on the north side and 2.65 ft. long on the south side, and averaged 0.93 ft. wide north-south. The channel was 0.9 ft. deep on each side. It was closed on the interior of the magazine by a metal grate. The base of this section of the channel averaged 120.6 ft. above sea level. The elevation of the upper surface of the stone forming the north side of the channel was 121.54 ft. above sea level. When the area was excavated there were two courses of the stone of the west wall preserved *in situ* spanning the channel. The lintel stone covered 1.8 ft. of the length of the channel. It was 0.35 ft. thick on the interior or east face of the wall, and 0.48 ft. thick on the west face. The stone above the lintel was 0.75 ft. on the interior or east face of the wall and 0.78 ft. thick on the exterior face of the wall. The elevation of the upper surface of this stone was 122.69 ft. above sea level.

The second part of the drain channel was formed by the exposed section of the wooden drain (Fig. 4). The wooden drain ran southwest-northeast toward the area of the stone curtain wall. The drain was built in the form of a box, similar to that of the other sections of wooden drain excavated at Fort Beausejour. The drain was exposed for a length of 1.37 ft. Both sides of the drain were well preserved, although the

lid was not preserved, if it had ever existed. The north side panel was 0.28 ft. wide and 0.1 ft. thick and was exposed for a length of 1.3 ft. The south side panel was 0.32 ft. wide and 0.15 ft. thick, and was exposed for a length of 1.22 ft. The bottom of the drain was 0.58 ft. wide and 0.08 ft. thick, and was exposed for a length of 1.37 ft. Thus the section of the wooden drain channel exposed was approximately 0.58 ft. wide.

The elevation of the upper edge of the north side panel was 121.03 ft. above sea level; that of the upper edge of the south side panel was 120.83 ft. above sea level. The elevation of the bottom of the drain was 120.71 ft. above sea level. Thus, the section of the wooden drain exposed was approximately 0.2 ft. deep.

The south side panel was braced by a vertical stake. The elevation of the top of the stake was 121.18 ft. above sea level.

The discovery of this section of wooden drain indicates that the 2E22L powder magazine had a drainage system similar to that of the other buildings at Fort Beausejour. However, this drain, while its construction is very similar to that of the other drains found within the fort, is much smaller in size. This may indicate that the section was built later than the rest of the system.

The Stone Drain in 2E16S

During the 1970 excavations a modern drainage system was installed around four of the five sides of the parade square. In the course of this work it was necessary to remove and record drain 3 and part of drain 5. It was also necessary to dig a deep trench along the south side of the parade square between Prince William and Prince Frederick Bastions. In the course of these excavations included in Operation 2E16, lots 2E16S6 to 2E16S24, part of a stone drain was located. This feature was an extension of the stone drain found in the excavations for drain 5 in lot 2E16Z5. This drain seems to have formed part of the original drainage system of the casemate located in Prince Frederick Bastion, Operation 2E20, and may have been built during the French occupation of Fort Beau-sejour.

The excavations in the area of the stone drain were carried out as part of sub-operation 2E16S, lots 2E16S6 to 2E16S24. The first section of this drain was exposed in lot 2E16Z5. Most of these lots were oriented toward the structure of the drain itself, although many were excavated stratigraphically.

Description of Features

The stone drain exposed in the excavations began approximately two feet west of the west wall of the 2E16 men's barracks (Fig. 5). From this point the drain ran in a shallow curve southwest turning west toward the middle of the parade square. Three sections of the drain were uncovered, totalling approximately 24 ft, 5 ft. of its length in lot 2E16Z5 (Fig. 9), 7 ft. of the outer edge of the north side in lots 2E16S11 and 2E16S17

and 12 ft. of the complete drain in lots 2E16S16, 2E16S20 and 2E16S24 (Figs. 10- 12).

The north section found in lot 2E16Z5 seems to have been the principle inlet. Here the channel was basically funnel shaped narrowing toward the west, from a width of 2.9 ft. to 0.45 ft. The inlet was roughly oriented toward the gorge of Prince Frederick Bastion and it is probable that the drain originally served, at least in part, to channel the surface run-off from the bastion. Unlike the rest of the channel, the base of this inlet was paved with large stones.

The main section of the channel had only a dirt floor and averaged 0.5 ft. wide varying from 0.45 ft. at the west end of the funnel to 0.55 ft. at the south edge of lot 2E16S16. The elevation of the bottom of the channel varied from 124.09 ft. above sea level in the stone floored inlet, to 123.71 ft. in the westernmost section uncovered.

The interior face of the sides of the drain was formed of two courses of roughly shaped masonry. This was supplemented by rubble at the outer face of the sides. The excavated sections of the north side averaged 1.7 ft. wide varying from a minimum of 1 ft. wide in the west-most section to a maximum of 2.7 ft. wide at the inlet.

The average elevation of the upper surface of the north side of the drain was 124.86 ft. above sea level varying from a minimum of 124.48 ft. above sea level at the western most end excavated to a maximum of 125.21 ft. at the inner edge of the inlet. Over most of the length of the north wall it was approximately one foot high although it was as low as 0.31 ft. high at the north end. Generally, the wall was lower toward its outer edges.

The excavated sections of the south wall averaged 1.7 ft. wide varying from a minimum of 0.85 ft. at the south side of lot 2E16S16 to a maximum of 2.5 ft. at the west most end of

the drain.

The average elevation of the upper surface of the south side of the drain was 124.63 ft. above sea level varying from a minimum of 124.11 ft. above sea level in the centre of the westmost section of the side to a maximum of 125.18 ft. at the north end next to the inlet. The south side averaged 0.83 ft. high but was 1.09 ft. high at the north end next to the inlet.

The channel which averaged approximately 0.9 ft. deep over most of the length excavated, appears to have been partially or completely covered to protect its being filled with earth. Remains of planking approximately 0.4 ft. wide were found in lot 2E16S9 with the grain aligned at right angles to the direction of the drain. These were probably the remains of a wooden cover for the channel. In lots 2E16S15 and 2E16S20 and lots 2E16S23 and 2E16S24 the channel was found to be covered by a layer of roughly shaped stones (Fig. 11). The average elevation of the upper surface of this layer was 125.5 ft. above sea level. There was evidence for a similar layer of stones at the north end of the drain. The relation of the wooden covering and stone covering of the channel is not apparent from the excavation evidence. Both may have been used indiscriminately.

Stratigraphy

The soil stratigraphy in the area surrounding the stone drain was quite simple, consisting of three layers. The first of these, Layer 1 on Figure 6,, the sod layer of loam - 7.5 YR 4/4 Dark Brown, extended over the entire area to an average depth of about 0.8 ft. but becoming thicker toward the centre of the parade square.

The second layer, Layers 3 and 4 of Figure 8, Layer 2

of Figure 8, of sandy-loamy clay, also extended across the area. Over most of the area the layer contained varying quantities of brick and mortar detritus. At the north end of lot 2E16S7, close to the 2E16 men's barracks, this brick and mortar detritus was especially concentrated. A great deal of pearl ware of a late 18th, early 19th century context and some charcoal and burnt wood was also found in this area. Beneath this layer at the north end ran a layer of burnt wood - Layer 3, Figure 7. The significance of this layer is not apparent from the evidence of excavation, but is likely that the deposit indicated the burning of a large amount of trash.

At the south end of the lot there was another concentration of brick detritus, elevation 125.34 ft. above sea level. Some of these bricks were flat-laid, surface elevation of 125.04 ft. above sea level, but no regular pattern was apparent. Several artifacts were found associated with this brick detritus, including a padlock, and fragments of an iron kettle.

Over the area of the drain this layer blended into one of sandy clay with small stones - 7.5 YR 4/4 Brown and 10 YR 3/4 Dark Yellowish Brown (Layer 2, Fig. 6; Layer 4a, Figure 7) which partially filled the drain channel.

Over most of the exposed length of the drain there was no cover of either stone or wood over the drain channel. There was no stratigraphic evidence that a cover of stones had been removed and it is probable that most of the length had been covered by wooden planking such as was found in lot 2E16S9. Since this wood was found at the base of layer 2, of Figure 6, this layer was either the backfill over the drain after it was built or the gradual accumulation over the exposed wooden cover. At the north end of the drain Layer 4a of Figure 7 is overlain by Layers 2 and 3 containing the burnt wood and charcoal and the Layer 4a must be earlier than Layers 2 and 3, if only slightly so.

The actual channel of the drain was filled with very sandy clay - 7.5 YR 4/4 Brown (Layer 5, Figure 7). This soil seems to have been deposited by the water flow in the drain.

The drain and the rest of the area was underlain by the normal subsoil of the area of Fort Beausejour - Layers 5, 6, Figure 6; Layer 6, Figure 7. This consisted of sandy clay - 7.5 YR 4/4 Brown.

At the southwest end of lots 2E16S14, 2E16S15 and 2E16S17 a few modern artifacts were found. When the stratigraphic cross-section of this area - Figure 6 - was drawn, the intrusion of the 1968 excavations in this area could be seen - Layer A - E. This intrusion did not extend across the 1970 excavations and did not disturb any strata essential to the interpretation of the features.

Interpretations and Conclusions

The drain found in this area was built of roughly shaped stone and rubble. The sides which were wide in proportion to the width and depth of the channel, were two courses high. At the north or inlet end, the drain was partially floored with roughly shaped flagstones. However, the rest of the channel, which sloped from northeast to southwest in a shallow curve had only a subsoil floor. The channel appears to have been at least partially covered with wood and stone - more wood being used than stone. This cover had almost completely disappeared at the time of excavation.

Although the artifacts have not been examined at the time of writing, the evidence of the location of the drain and the adjacent soil stratigraphy indicates that the drain may have been originally built to serve the casemate in Prince Frederick Bastion, draining the run-off towards the centre of the parade square. Since the building of the extant men's barracks in

the period around 1785 or later seems to have cut the line of the drain and finally buried it, the drain must pre-date the barracks. However, beyond this the drain could be either French or British in origin, although a French context does seem probable since the other stone drains in the fort area have been related to French structures. This drain may have formed part of a drainage system serving the French structures on the site of 2E16 and in front of the 1756 British entrance.

The Beams Found in Operation 2E26

In the course of the 1970 season of excavation at Fort Beausejour, the stone retaining wall structures remaining from the British Gate between Prince William and Prince Frederick Bastions (Operation 2E26) were stabilized. It was deemed necessary to lay a concrete pad below ground level on which to base the stabilized wall structures. During the excavations for this concrete pad, three wooden beams were located approximately 6.5 ft. below the level of the adjacent parade square. The lengths of the beams were oriented east-west.

The first beam found was located on the north side of the area of Operation 2E26 and almost immediately below the north wall of the 2E26 gate structure. It was recorded in lot 2E26W1. The second and third beams were lying end to end on the south side of the area of Operation 2E26 almost immediately below the south wall of the gate structure. These two beams were recorded in lot 2E26X1, the eastern beam designated as beam 1 and the western beam, beam 2. These beams appear to have been the sleeper beams for a casemate structure within the curtain wall between Prince William and Prince Frederick Bastions. This supposition is supported by historical data and by the presence of five mortises in the upper surface of beam 2 in lot 2E26X1. There were no mortises in beam 1 in lot 2E26X1.

On the south side of the beam recorded in lot 2E26W1 a Roman Numeral I was found carved next to mortise 1, at the south end of the beam, a numeral II next to mortise 3 and a numeral III next to mortise 5. A similar numbering was found on beam 2 recorded in lot 2E26X1 and this suggests that both were cut at the same time.

Two vertical wooden posts were located during the excava-

tions in suboperation 2E27A, adjacent to the west end of the 2E26 gate structure and overlapping the west ends of the beam in 2E26W1 and beam 2 in 2E26X1, which appear to be the only surviving evidence of the superstructure originally related to the sleeper beams. The first of these, removed in lot 2E27A23 was found in a vertical position above the west end of the beam in lot 2E26W1. This post was finished with a tenon on the lower end. The other post, without a tenon, was found in a vertical position above the west end of beam 2 in lot 2E26X1. (A few wooden dowels were found near the beams).

Two stone features each consisting of two low courses of roughly-shaped stone and rubble were located on either side of the two beams in lot 2E26X1. Two similar features seem to have been located on either side of the beam in lot 2E26W1, but unfortunately these were almost completely destroyed by the excavation machines before archaeological excavation was begun. These features seem to have been designed to brace the sleeper beams and stabilize them under the weight of the superstructure.

Description of Features

The average elevation of the beam in lot 2E26W1 was 119.83 ft. above sea level. Beam 1 in lot 2E26X1 seems to have been somewhat out of place as excavated. The average elevation of the upper surface of the beam was 119.85 ft. above sea level at the west end. Thus the surface of a floor level based on these beams would have been at an elevation of approximately 120 ft. above sea level.

The Beam in 2E26W1

The beam recorded in lot 2E26W1 averaged 15.72 ft. long east-west. The horizontal width averaged 0.96 ft. The vertical thickness of the beam averaged 0.86 ft. It had five rectangular mortises cut into the upper surface which were numbered from east to west during recording.

The spacing between these mortises averaged 2.5 ft. The east end of mortise one was 0.8 ft. from the east end of the beam. The west end of mortise five was 0.3 ft. from the west end of the beam.

The mortises were of two different sizes. The first, third and fifth mortises averaged 0.88 ft. long; the second and fourth mortises averaged 1.02 ft. long. The difference between lengths of the mortises is due to their probable use. The shorter mortises held only one upright each; the longer mortises held two diagonal beams which braced the uprights. Otherwise, the dimensions of the mortises had an overall consistency, averaging 0.26 ft. in width and 0.45 ft. in depth. The line of mortises was regularly spaced 0.44 ft. in from the north side of the beam and 0.22 ft. in from the south side of the beam. The uprights in mortises 1, 3 and 5 were each secured by one horizontal dowel; there were two horizontal dowels through mortises 2 and 4. In each case the dowels were evenly spaced horizontally. The position of the holes averaged 0.14 ft. below the upper surface of the beam, 0.75 ft. above the lower surface of the beam and 0.34 ft. above the base of the mortise. The dowel holes averaged 0.09 ft. in diameter. Some dowel fragments were found during the excavation and recording of the beam. The uprights positioned in mortises 1 and 2 were further secured by three evenly-spaced vertical dowels. The upright in mortise 3 was secured by one vertical dowel, although the base of the mortise was marked with scars from a brace and bit which may indicate

that other vertical dowels were intended. The exact nature of these dowels, which were also present in three of the mortises of beam 1 of lot 2E26X1, is not absolutely certain. They were not driven up through the lower surface of the beam, since the dowel holes do not extend through the beam. It is possible that the vertical dowels were one piece with the beam fitted into the mortise and its tenon, and were lowered into holes bored into the bottom of the mortises. However, the difficulty of making the tenons for such a joint makes it more likely that the joint consisted of three parts. Holes were most likely drilled into both the tenon and the base of the mortise into which individual dowels were fitted to brace the joint. There is great variation in the depth of the dowel holes among the mortises. And it appears that when the casemate was demolished and the uprights removed, the dowels were broken off rather than being completely removed. These dowel holes averaged 0.14 ft. in diameter; there were no vertical dowels in mortises 4 and 5

Mortise 2 included three vertical dowel holes. However, the western and centre dowel holes do not seem ever to have been fitted with dowels, because the western dowel hole was completely covered and the central dowel hole was partially covered by a triangular wedge that was fitted into the west end of the mortise to give it a sloping west end. This wedge was basically triangular in shape, 0.43 ft. long horizontally, 0.45 ft. high and 0.6 ft. long on the sloping side. It was approximately as wide as the mortise and its height was such that it did not protrude above the surface of the beam. The sloping side of the wedge was not completely flat. Instead there was a notch 0.32 ft. up from the lower end, 0.08 ft. deep and 0.06 ft. wide. This appears to have been cut to allow the western horizontal dowel to be driven through. It is possible that the wedge is not part of the original struc-

ture of the mortise, but the correspondence of the notch with the dowel hole and the existence of the slope-sided mortises in beam 2 of lot 2E26X1 and the existence of a similar wedge in mortise four of the beam in lot 2E26W1 seem to confirm that this is a part of the original structure. The wedge seems to be an improvised measure, that could indicate that the beam had not been correctly cut and had to be adapted to the required use.

Mortise 4 was similarly modified by the addition of a triangular wedge at the east end of the mortise. This wedge was approximately as wide as the mortise and was 0.3 ft. long horizontally, 0.4 ft. high with a slope 0.52 ft. long. The wedge did not cut across the west dowel hole and therefore was not notched as was the wedge in mortise 2.

Levelling Blocks

Seven wood fragments were found under the beam in lot 2E26W1. These were probably building scraps. Several appear to have been used to adjust the level after the beam was in place.

Four sets of levelling blocks were found under the beam in lot 2E26W1. The first set consisted of two small wood fragments resting on a piece of planking. This set was located under the west end of the beam extending approximately 0.5 ft. to the west of it.

A piece of planking, was located approximately 3 ft. from the east end of the beam and was also not immediately associated with any other fragments.

Two other superimposed wood fragments were at the east end of the beam and extending about 0.5 ft. beyond the end.

Dowels

Two dowels were found in lot 2E26W1, associated with the beam. Both of these dowels seem to have been shaped by cutting flakes off a squared stake. The first dowel was 1 ft. long and 0.07 ft. square in cross section. The second dowel was 1.15 ft. long and 0.09 ft. by 0.08 ft. in cross section.

The Post Found in Lot 2E27A23

The wooden post which was found in a position above mortise 5 at the west end of the beam in lot 2E26W1 was originally located in lot 2E27A15 and 2E27A20 although it was recorded as part of lot 2E27A23 (Fig. 14). The post was not found in a vertical position but was leaning to the west. The elevation of the upper end of the post was 123.58 ft. above sea level, or 1.43 ft. above the upper surface of the beam in lot 2E26W1.

The post was 4.22 ft. long averaging 0.64 ft. wide and 0.44 ft. thick. However, the post became slightly wider and thicker toward the lower edge. The upper end of the post was very badly preserved. The lower end had been cut to form a tenon that would fit a mortise with inclined sides. The post was also secured in position by a dowel driven through the tenon of which a small fragment remained *in situ*. This dowel hole was approximately 0.1 ft. in diameter.

Since the tenon on this post was made to fit a mortise with inclined sides it is unlikely that the post was cut to fit any of the mortises in the two beams under discussion except for mortises 2 and 4 in each of the beams. The tenon of the post is small enough to permit the fitting of two posts in each of these four mortises. This hypothesis is also supported by the presence of only one dowel hole in the tenon when there are two in each of the mortises with inclined

sides. If this hypothesis is true each of the two beams with mortises would support seven posts. Three of these would be set up vertically in mortises 1, 3, and 5. Mortises 2 and 4 would each contain the tenons of two posts, similar to the post numbered 2E27A23-1 leaning in appropriate directions to brace the vertical posts, the two posts in mortise 2 bracing the posts in mortises 1 and 3, and the two posts in mortise 4 bracing the posts in mortise 3 and 5. The double bracing of the centre posts in mortise 3 of each beam may indicate that it was slightly higher forming the king post of a slightly peaked roof. However, the extra bracing would add stability to the structure, important when the weight of the curtain wall on the roof is considered.

The Two Beams in Lot 2E26X1

Two beams were recorded in Lot 2E26X1. During the actual field recording these were numbered 1 and 2 from east to west. Of these two, beam 2 will be discussed first because it is the more important.

Beam 2 averaged 15.32 ft. long east-west and 0.86 ft. wide.

The beam had five rectangular mortises cut into the upper surface, which are numbered from east to west.

The form of these mortises and the use of vertical and horizontal dowels to secure the uprights placed in the mortises was very similar to that of the beam in lot 2E26W1. There was however, by comparison, more variation in the dimensions of each component. The spacing between the mortises averaged 2.24 ft., but varied from a minimum of 2.1 ft. to a maximum of 2.5 ft. The east end of mortise 1 was 0.36 ft. from the east end of the beam; the west end of mortise 5 was 0.28 ft. from the west end of the beam.

The mortises were of two basic sizes. The first, third

and fifth mortises averaged 0.9 ft. long; the second and fourth mortises averaged 1.68 ft. long. As in the beam in lot 2E26W1, the difference between the lengths of the mortises is due to their probable use. The shorter mortises held only one upright each. The longer mortises held two diagonal beams which braced the uprights. The beam in lot 2E26W1 had adapted the longer mortises to their function by the insertion of wedges to give the mortises sloping sides. Mortises 2 and 4 of beam 2 of lot 2E26X1 were cut with sloping sides and did not have to be altered. There was a considerable difference between the mortises with regard to this slope. In mortise 2 the incline measured 0.55 ft. along the slope and 0.4 ft. horizontally. In mortise 4 the incline measured 0.47 ft. along the slope and 0.31 ft. horizontally. However, the difference in measurements does not affect the use of the mortise itself. Since the second and fourth mortises were longer than the matching pair in the 2E26W1 beam, the braces must have been longer east-west in cross-section than the braces fitted into mortises 2 and 4 of the 2E26W1 beam. The mortises averaged 0.4 ft. deep, less than those of the 2E26W1 beam. However the width was the same, averaging 0.42 ft.

The uprights in mortises 1, 3 and 5 were secured by one horizontal dowel each; there were two horizontal dowels through mortises 2 and 4. In each case the dowels were evenly spaced horizontally. The position of the dowel holes averaged 0.1 ft. below the upper surface of the beam, 0.8 ft. above the lower surface of the beam, and 0.28 ft. above the base of the mortise. The dowel holes averaged 0.08 ft. in diameter.

As was the case with the beam in lot 2E26W1, vertical dowels were used to secure the uprights in some of the mortises. There were three evenly-spaced vertical dowels in

mortises two and three. There were five vertical dowel holes in the base of mortise four, one in each corner and one in the middle of the south side of the bottom. These dowels averaged 0.16 ft. in diameter, varying from a minimum of 0.09 ft. to a maximum of 0.21 ft.

Levelling blocks

Four fragments of wooden planking which probably served as levelling blocks for the beam were found under beam 2 of lot 2E26X1. Of these, the second was found on top of the first. The first and second fragments were located under the east end of the beam.

Other Wood Fragments

Five dowels were found in lot 2E26X1 in association with beam 1. Two of these seem to have been formed by cutting flakes from the sides of squared stakes. One was complete and was 1.35 ft. long and 0.08 ft. by 0.08 ft. in cross-section. The other was not preserved completely. It was 0.6 ft. long and 0.09 ft. by 0.09 ft. in cross-section.

One of the dowels was oval-shaped in cross-section; length-wise flakes had been cut to point the end. It was 1.3 ft. long and 0.08 ft. by 0.07 ft. in cross-section. Another, incompletely preserved, without a point, was almost round in cross-section but seems to have been a tree branch stripped of bark rather than a piece of turned wood. It was 0.61 ft. long and 0.06 ft. by 0.08 ft. in cross-section.

The fifth wood fragment may not actually be a dowel as it was 3.6 ft. long. It averaged 0.11 ft. in diameter.

Two wedges were found near beam 1, neither of which were under the beam. One was quite simple, formed by cutting two converging flakes, one from each side of a rough stake 1 ft.

long and averaging 0.15 ft. by 0.14 ft. in cross-section. The second wedge was 1 ft. long, averaged 0.28 ft. wide and was 0.09 ft. thick at the wide end. The wide end was edged with a chamfer that averaged 0.04 ft. wide. This formed a flat, raised area 0.24 ft. long and 0.06 ft. wide.

Another wood fragment was found near the beam which averaged 1.28 ft. long, 0.39 ft. thick and 0.61 ft. wide.

Beam 1 in lot 2E26X1 averaged 6.35 ft. long and 0.82 ft. wide. There were no mortises cut into the upper surface of the beam.

The purpose of this beam cannot be satisfactorily explained from the evidence of excavation. That it is flanked by the same rough stone feature as beam 2 indicates that it is basically in its original position. However, since it was not matched by a beam at the east end of the beam in lot 2E26W1 it does not appear to have been a functioning part of the structure. Since there are no mortises in its surface into which vertical or inclined posts could be fitted it does not appear to have been a functioning part of the structure based on the other two beams.

The Stone Bracing Walls (Fig. 14)

Along each side of both beams in lot 2E26X1, beam 1 for the western half of its length and beam 2 for its entire length, was a low limestone wall. There is evidence that similar walls existed along either side of the beam in lot 2E26W1, however, they were almost completely removed during construction work before archaeological excavation began. Each of the wall was two courses high, the lower course being hammer dressed, the upper course being of shaped rubble mixed in random pattern. The elevation of the upper surface of the north wall was 119.78 ft. above sea level. The elevation of

the upper surface of the south wall was 119.89 ft. above sea level at the east end and 119.76 ft. above sea level at the west end.

These walls definitely seem to have been built to brace the beams against the lateral pressures of the weight of the structure they supported. However, since they flanked not only beam 2 and the beam in lot 2E26W1, but also the apparently non-functional beam 1, the full purpose behind their building is not clear.

Stratigraphy

The stratigraphic evidence associated with the structure is not likely to give any real evidence for dating the structure. The fill above and below the beams was of the reddish brown, stoney and sandy clay found over the entire fort area. It did not appear to have been disturbed at all as would be expected to permit the building of this structure which was partially below the natural ground surface and contained within the width of the retaining wall.

The only stratigraphic evidence pertaining to the structure was the presence of a layer of wood fragments in the face of the curtain wall exposed by the excavations on the south side of operation 2E26. This layer which probably indicates organic fill and building waste placed on the roof of the structure, extended about 8 ft. east-west. It varied in thickness from 0.3 ft. at the east end to 0.7 ft. at the west end. The elevation of this layer was 124.03 ft. above sea level. This layer probably indicates the approximate level of the roof after the collapse of the structure.

Interpretations and Conclusions

Two of the beams found in the excavations in Operation 2E26

the beam in lot 2E26W1 and beam 2 in 2E26X1 provide firm evidence for a casemate structure in the curtain wall between Prince William and Prince Frederick Bastions. This structure was based on two sleeper beams aligned east-west across the thickness of the curtain wall and set 20 ft. apart. Each of the beams supported three vertical posts in mortises in the upper surface of the beams, one at each end and one in the middle. These vertical posts were braced by inclined posts, two set in each mortise between the vertical posts. The outer posts were braced by one inclined post in the interior side of each, the centre posts were each braced by an inclined post on each side. Each of the sleeper beams was braced by a low, roughly built stone wall on each side. There is no evidence on which to describe the roof construction of this structure but it could have been either flat or slightly peaked, although on analogy with other casemates at Fort Beausejour, a flat roof seems likely.

The evidence of excavation does not provide any clue to the relationship of beam 1 of lot 2E26X1 to the casemate. Although it was structurally included with beam 2 and appears to have been laid at the same time. This structure definitely pre-dates the British gate structures, built in 1755, excavated in Operation 2E26. Since this entrance was constructed in the first year of British occupation, it is unlikely that the casemate was built by the British. However, there is little evidence to indicate the dates during the French occupation when it was built. The 1751 plan of Fort Beausejour drawn by Franquet shows a section through the curtain wall in this area but does not indicate a casement. The plan of the fort signed by La Jonquiere and dated 1752, shows in a section through a typical curtain wall, a much less elaborate timber casemate than the one discussed here. Since the fortifications were not rebuilt as earth walls until this time or because it is

more elaborate than that indicated on the map, it may have been built between 1752 and 1755. The casemate was probably levelled to the sleeper beams and the area cleared in 1755 when the British entrance was built, but it may have fallen into disuse and collapsed at an earlier date.

Excavations in Operation 2E27

During the installation of the modern drainage system around the perimeter of the parade square in 1970, it was necessary that a trench be dug along the interior face of the curtain wall between Prince William Bastion and Prince Frederick Bastion, to connect the drainage of the powder magazine in Prince William Bastion (2E22) to the main drainage system. A men's barracks was shown on the "Plan du Fort de Beausejour" drawn in 1751 by Franquet (Herst and Swannack 1970: Fig. 2), and on the "Plan et Profil du Fort de Beausejour 1752" signed by La Jonquiere (Herst and Swannack 1970: Fig. 3). After the English occupied the fort, the curtain wall between these bastions was redesigned to contain the main entrance into the fort. Two guard houses are shown on the "Plan of Fort Cumberland", drawn in 1779 by Spry (Herst 1970: Fig. 3) as flanking the interior side of this entrance. The guard house (2E25) on the northeast side of the gate was excavated in 1968 (Baker 1970). During the 1970 excavations the area was not completely excavated and though several features were located and recorded, it was not possible to get an overall view of the area. Accordingly, the interpretation of these features lacks the co-ordination that would otherwise have been possible. None of the major features were destroyed by the work on the drain.

The excavations in this area were designated as Operation 2E27, suboperation 2E27A. Principally the excavations were along a narrow strip paralleling the curtain wall but the area was wider at the west end of the area.

Description of Features

The Wall Found in Lot 2E27A3 - Wall A

Excavation in lots 2E27A3, 2E27A6 and 2E27A9 located a wall line running parallel to the curtain wall. The slump of the interior face of the curtain wall had covered the wall (Figs. 20 and 21). The wall consisted of large shaped stones but, though two courses were apparent, the stones were not in their exact original positions (Fig. 21). One of the stones was hammer dressed. The individual stones had been shaped so that the side facing the curtain wall was regular and well-constructed. The other sides of the stones were only very roughly shaped to fit each other. The upper and lower surfaces of the stones were basically flat to make regular courses of stone possible.

The 12 foot excavated section of Wall A extended the full length of lot 2E27A3. The wall was 1.05 ft. wide at the east end and 1 ft. wide at the west end. The average elevation of the upper surface of Wall A was 126.46 ft. above sea level.

Several medium sized stones which appear to have belonged to Wall A were found between the wall and the main body of the curtain wall. The character of these stones was the same as that of the stones *in situ* in the wall. The average elevation of these stones effectively blocked further excavation in the narrow area between Wall A and the curtain wall.

The Wall Found in Lots 2E27A16 and 2E27A17 - Wall B

The wall found in lots 2E27A16 and 2E27A17 (Wall B) ran east-west along the north side of the area of excavation (Fig. 21). The length was exposed in these lots and in the stratigraphic cross-section through 2E27A and totalled 11.7 ft. This appears to be all of the wall that survived. Only one face and a corner of Wall B were exposed - the north face of Wall B is in the unexcavated area north of 2E27A. The section of the width

of Wall B excavated averaged 2.2 ft. wide varying from a minimum of 1.8 ft. at the west end to a maximum of 2.8 ft., six feet from the west end of the wall. The west end of Wall B appears to have been an actual corner of the building for which the wall was the foundation.

The south side of Wall B. was constructed of roughly shaped medium sized stones, giving a more or less regular appearance. At the west end a portion of a second course of stone remained. The south face appears to have been the exterior face of the wall. Behind this facing, the core of the wall was rubble-filled. This wall was not as well built as the wall found in lot 2E27A3 and it is unlikely that they formed part of the same feature.

The average elevation of the upper surface of Wall B was 125.73 ft. above sea level.

West of the corner of the wall, between the end of the wall and the west limit of excavation, were located several flat stones. Several of these stones formed a roughly level surface, elevation 124.86 ft. above sea level, approximately 1.2 ft. below the upper surface of the wall. This surface may represent some form of pavement, perhaps serving as a splash drain at the base of the wall.

The Rubble Area Between the Walls Found in Lots 2E27A16-2E27A17 (Wall B) and in Lot 2E27A3 (Wall A)

The area between these two walls contained a large concentration of brick and stone rubble (Fig. 17). Some of this rubble was directly associated with the rear side of Wall A. The upper surface of this rubble averaged 126.42 ft. above sea level. An area of decayed wood was found next to the north side of Wall A. The feature, surface elevation 125.38 ft. above sea level, measured 1.15 ft. north-south by 1.11 ft.

from the east limit of the lot and 3.8 ft. from the south limit of the lot. The exact relation of this feature with Wall A was not clear because it was not possible to determine whether it extended under the north face of the wall.

A short rubble wall (Wall C) was located in lot 2E27A28 adjacent to the south face of the wall found in lots 2E27A16-2E27A17 (Fig. 21). Wall C was 7.35 ft. long extending from the east limit of excavation and stopping 4.65 ft. short of the west limit of excavation. The wall consisted of one course of roughly shaped stones and was only one course wide. The average elevation of the upper surface of Wall C was 124.7 ft. above sea level. The base of this wall coincided with the base of the stone and brick rubble concentration between the two walls.

The excavation of the area between Walls A and B did not solve the problem of their relationship. Both of the walls were finished so as to indicate that only the south faces were visible. This and differences between their construction, Wall A being much better built, seems to indicate that the walls did not form part of the same structure. The rubble between the two walls could have come from either of the walls and does not provide any unmistakable indication of the sequence of building and abandonment. However, further excavation exposing the full extent of the features would clarify the relationship.

The Wall Found in Lot 2E27A21 - Wall D

A wall of roughly shaped stone and rubble was located in lot 2E27A21 running at right angles to the curtain wall across the width of the lot. On the east side Wall D was two courses high. On the west side, the wall was more roughly built although the stone was still laid in courses. The centre of

the wall appears to have been rubble-filled. The average elevation of the upper surface of the wall was 125.66 ft. above sea level to a maximum of 126.11 ft. above sea level on the north corner of the excavated section.

The line of Wall D is at right angles to the line of Walls A and B but, as the area was not completely excavated, it was not possible to state whether the walls were associated in the same feature.

A large amount of brick and stone rubble and detritus was found on both sides of Wall D at an average elevation of 125.59 ft. above sea level. A concentration of shell and bone, elevation 125.78 ft. above sea level was found at the west end of the area. Excavation did not reveal the exact nature of this feature, but it was probably a small garbage dump.

The Wall Found in Lot 2E27A42 - Wall E

Excavation in lot 2E27A42 exposed a wall line consisting of one course of rubble running parallel to the north wall of the 2E22L powder magazine. The west side of Wall E averaged 1.6 ft. from the exterior face of the 2E22L wall, varying from 1.4 ft. at the south end to 1.8 ft. at the north end. The wall was 1.4 ft. wide at the north end and 1 ft. wide at the south end and averaged 0.7 ft. high. It was only one course high and the average elevation of the upper surface of Wall E was 125.28 ft. above sea level.

The area between Wall E and the north wall of the 2E22L powder magazine contained a large concentration of mortar detritus. Below this mortar detritus some French slip-decorated coarse earthenware was found.

The relation of Wall E with the other features located in 2E27A was not apparent because of the small area excavated. However, the very different manner of construction seems to

suggest that the wall is not directly related with the others located in 2E27A.

The North Wall of the 2E22L Powder Magazine

When excavation was finished in lots 2E27A42 to 2E27A48 it was discovered that the north wall of the 2E22L powder magazine was not as thick as previously supposed. At an elevation of 125.6 ft. above sea level, which seems to have approximately corresponded with ground surface, a course of medium-sized shaped stones were laid on the ground, along the exterior face of the wall (Fig. 19). This course of stone increased the thickness of the wall by approximately 1.3 ft., and was probably designed to enable the building of a more massive wall on the lower foundations of the powder magazine.

The exterior face of this wall was rubble built with crumbly yellow mortar. The base of the wall was at an elevation of 121.5 ft. above sea level. The fill immediately adjacent to the exterior face of the wall contained French slip-decorated coarse earthenware.

Stratigraphy

The interpretation of the stratigraphy associated with the features excavated in sub-operation 2E27A is complicated by the incomplete nature of the excavations. Had the area of these features been completely excavated, the relationships of the soil strata would have been much more intelligible than it is at this time. However, certain relationships are apparent.

The soil configuration in this area consisted of five main strata. The lowest of these, which consists of sandy clay and clay with some small stones, 5 YR 3/3 Dark reddish brown to 5YR 4/4 Reddish brown, is the sub-soil of the area.

This stratum shows on Figure 17 as layers 8 and 9, on Figure 18 as layer 4 and on Figure 19 as layer 4.

Above this stratum, stratum 2 is primarily associated with Walls C, D, and E. This stratum is below and round these features, but does not cover them, and it therefore appears that these walls are basically contemporary. On Figure 17, this stratum is shown as layers 3 to 7, 11 to 13 and 16, 20 and 21; on Figure 19 as layers 3a and 3b, and on Figure 18 as layer 3. The approximate base level of this stratum is 123.5 ft. above sea level. The stratum was disturbed at the west end by the foundation trench for the north wall of 2E22L powder magazine, dating from ca. 1813, and at the east end by the work of grad-and filling associated with the construction of the British gate in 1756. Thus, this stratum appears to date from before 1756 and to the period of the French occupation of the fort.

Stratum 3 consists of two related parts. The first of these is shown as layer 2a on Figure 17, and consists of a dense concentration of brick, stone and mortar detritus lying between walls A and B. The stratum does not cover walls A and B, but does cover walls C, D and E, and may be debris from an earlier structure that was used as fill for the building of the structures associated with walls A and B. The stratum has the same relationship to both Wall A and Wall B, and it therefore appears that these walls are approximately contemporary. Since Wall B. is most likely to be associated with the 1756 British guardhouse in this area, this would be the approximate date for the accumulation of the earliest part of the stratum. The stratum may also contain debris from the deterioration of the structures represented by walls A and B.

Interpretation and Conclusions

The excavations carried out in sub-operation 2E27A were not

extensive enough to give a clear picture of the features located. None of these features was completely excavated and their relation to each other can only be hypothesized. The two principle features excavated, walls A and B, seem from stratigraphic evidence to be contemporary. The historical evidence indicates that Wall B is probably part of the foundation structure of the western guardhouse built by the British in 1756. The nature of the structure represented by Wall A is uncertain, but it may be part of a sally port corridor leading to the gate. There is, however, no indication in the documentation of a feature in this area. The stratigraphic evidence that linked walls A and B also showed that the building of the British gate had been accompanied by extensive grading and levelling on the interior side of the gate to create a suitable roadway. Unfortunately the stratigraphy did not give any firm indication of the date when these structures fell derelict.

The stratum associated with walls A and B covered an earlier stratum, in which walls C, D and E were located. The structure of these walls and the historical documentation of the fort gave little indication of these features. However, since they predate the features associated with the first period of the British occupation, walls C, D and E probably date from the period of the French occupation of the fort.

At the west end of the area excavated, the stratum associated with walls A and B was interrupted by the foundation trench for the north wall of the 2E22L powder magazine. This trench was not very large and did not disturb the features in the adjacent area. The trench was backfilled with fill containing artifacts dating from the period of French occupation of the site. However, the provenience of this fill is not known.

The second section of stratum 3 is represented by layers

2b, 2c and 10 of Figure 18. These layers consist of loamy sandy clay containing brick stone and mortar detritus similar to that of the concentration in the first section of stratum 3. In this area the layers of stratum 2 have been cut away to form a depression sloping down to the east to an elevation of approximately 123.3 ft. above sea level. Above this the fill layer is approximately one foot thick. The surface of the fill layer was not level, but formed a shallow depression similar to the one described above. This soil configuration is located immediately inside the British gate and seems to indicate that considerable grading and filling was undertaken in the area to create a firm and convenient roadway into the parade square. Evidence of this grading and filling was probably present on the other side of the entrance, but the stratigraphy in this area was destroyed by collapse before it could be recorded. Because this configuration of the soil layers is closely related to the building of the British gate in 1756, this section of stratum 3 is closely dateable to this period, as was the first section of the stratum.

Stratum 4 is related to the building of the stone powder magazine in 2E22L, and is dateable to ca. 1812. The foundation trench along the exterior face of the north wall of the magazine shows on Figure 17 as layer 15, part of layer 16 and layers 17 to 19 and 22. The lower half of the wall was backed against the side of the main building trench. The main building trench was expanded on the exterior side of the line of the wall from an elevation of approximately 123.2 ft. above sea level. The resulting foundation trench along the exterior face of the wall was approximately 2.5 ft. wide at the bottom and widened to approximately 3.5 ft. This trench was not so wide as to disturb walls B and E. However, it may have disturbed the western, unexcavated portion of Wall A.

Stratum 5 consists of fill over the area of the features excavated. This fill is indicated on Figure 17 as layers 1 and 14, on Figure 19 as layers 1, 2, 5, 6 and 7, and on Figure 16 as layers 1 and 2. The accumulation of this stratum followed the deterioration of the structures represented by Wall A (Figure 20) and Wall B, and consists of two distinct types of fill. Layers 2, 5, 6, and 7 on Figure 19 and layer 2 on Figure 16 seem to represent slump from the inner face of the curtain wall across the features. These layers contain mortar detritus that seems to have leached from the joints of Wall A. Layer 1 on Figures 17, 18 and 19 represents the accumulated top soil over the area. Since the deposition of this stratum is preceded by extensive dereliction in the area of the main gate of the fort, the stratum probably dates to the period after the final abandonment of the fort by the British army.

Tables

Table 1. Elevation of the upper surface of the bottom

West end of drain (section one)	119.09 ft. ASL
West end of section two	119.09 ft. ASL
West end of section three	119.29 ft. ASL
West end of section four	119.21 ft. ASL
West end of section five	119.24 ft. ASL
West end of section six	119.55 ft. ASL
West end of section seven	NA
West end of section eight	119.83 ft. ASL
East end of drain (section eight)	120.17 ft. ASL
Difference from East end to West end	1.08 ft.

Table 2. Co-relation of the stratigraphic soil layers of Figures 6, 7 and 8

<u>Figure 6</u>	<u>Figure 7</u>	<u>Figure 8</u>
1	1	1
2	-	2
4	2, 3, 4a	-
6	4b	4
-	5	-
-	-	3

Table 3. Co-relation of the stratigraphic soil layers of Figures 18, 19 and 20

<u>Figure 18</u>	<u>Figure 19</u>	<u>Figure 20</u>
1	1	1
-	2	2
2a	3a	-
3	3b	-
8	4	-
16	-	3a
16, 20	-	3b
13	-	4

References Cited

Baker, S.G.

1970

"Preliminary Report on the 1755 British Guardhouse at Fort Beausejour, New Brunswick." Manuscript on file, National Historic Parks and Sites Branch, Ottawa

Dendy, W.B.

1968

"Preliminary Report of 1966 Excavations Conducted at Fort Beausejour National Historic Park, Aulac, New Brunswick." Manuscript on file, National Historic Parks and Sites Branch, Ottawa.

Herst, D.L.

1970

Preliminary Report on the Excavation of the Officers' Quarters (2E19) and the French Casemate (2E13) at Fort Beausejour, N.B. Manuscript Report Series No. 14, National Historic Parks and Sites Branch, Ottawa

Herst, D.L. and J.D. Swannack

1970

"Fort Beausejour: Historical and Archaeological Summary Report." Manuscript on file, National Historic Parks and Sites Branch, Ottawa.

Moussette, Marcel

1969

"Preliminary Excavation Report of Operation 2E22, 2E24 at

Fort Beausejour, 1969." Manuscript on file, National Historic Parks and Sites Branch, Ottawa.

Zeller, A.

1968

"Excavation of Drainage System at Fort Beausejour." Manuscript on file, National Historic Parks and Sites Branch, Ottawa.



1 Key plan showing the location of operations
2E16, 2E22, 2E23, 2E26, 2E27. (2E-68-101-1B)

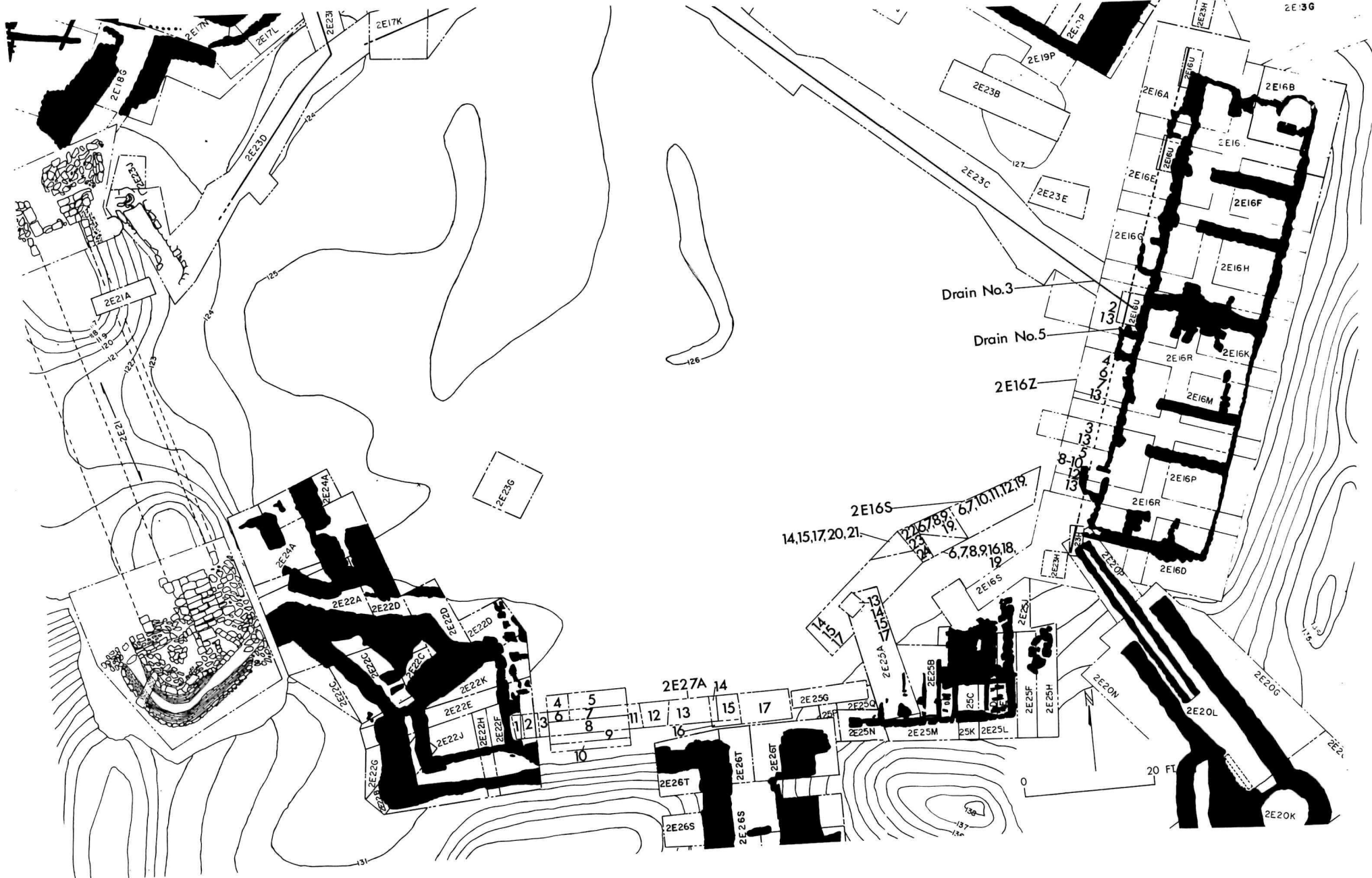

2 Key plan showing 2E16, 2E27 and drain No. 3 and No. 5. (2E-68-101-1C)

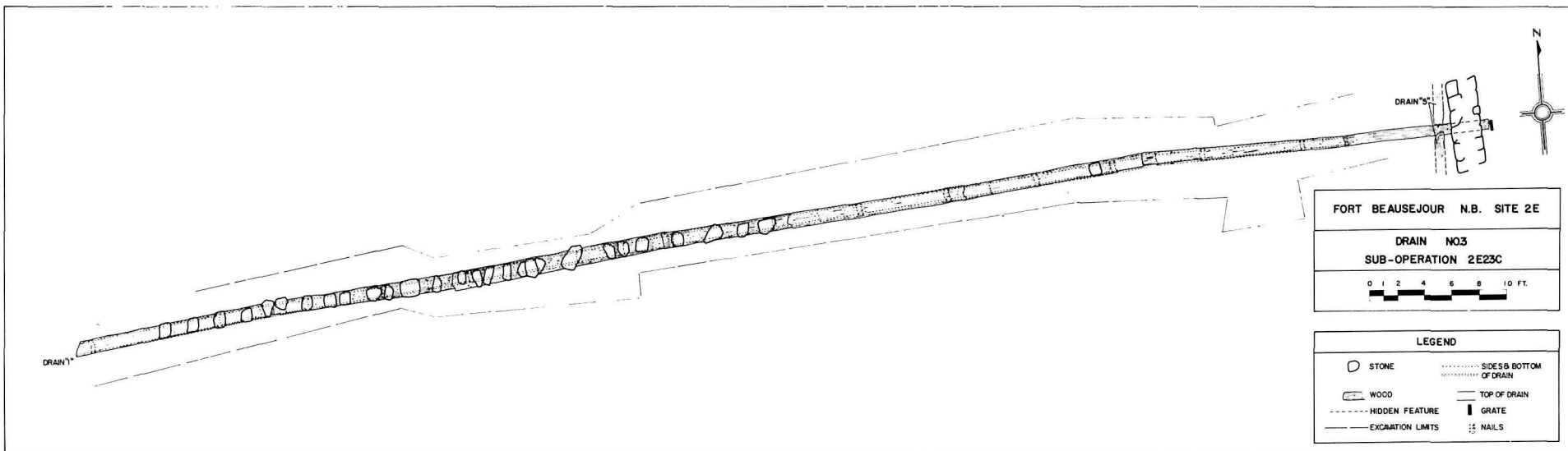

55

3 Site plan of Drain 3, suboperation 2E23C (2E-68-102-6).

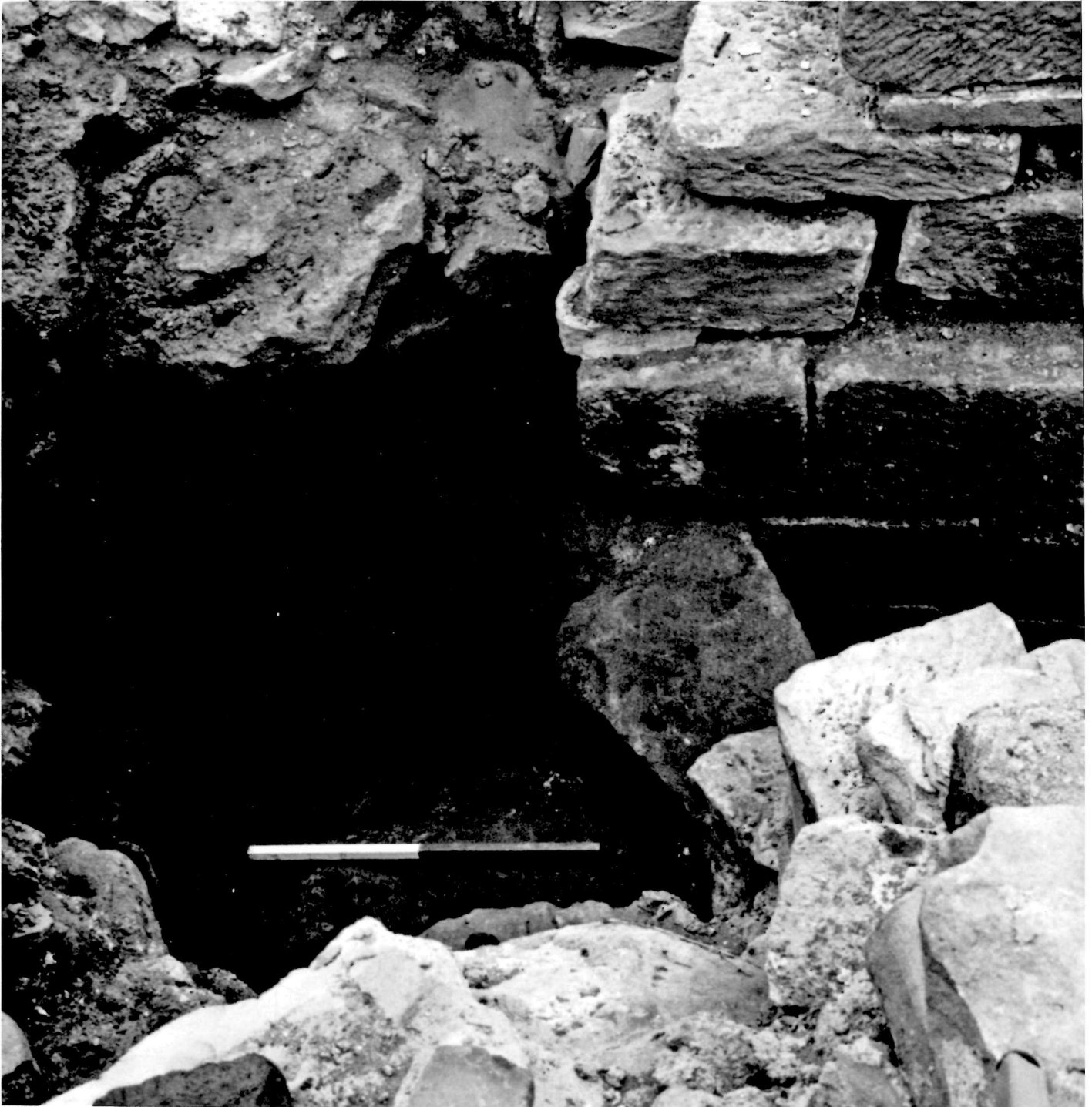

4 Post-excavation view of the wooden drain, with the camera facing west. Included is a two foot scale north-south at right angles to the north wall of 2E22L (2E-3543 X).

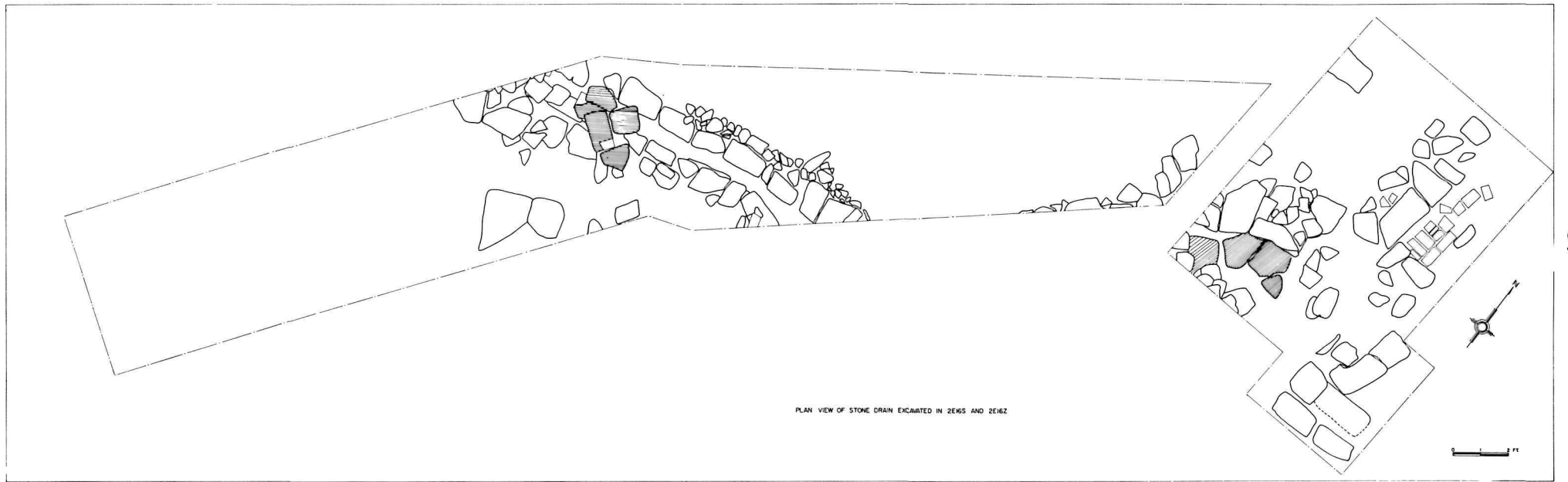

5 Plan of the stone drain excavated in 2E16S and 2E16Z (2E-71-102-1).

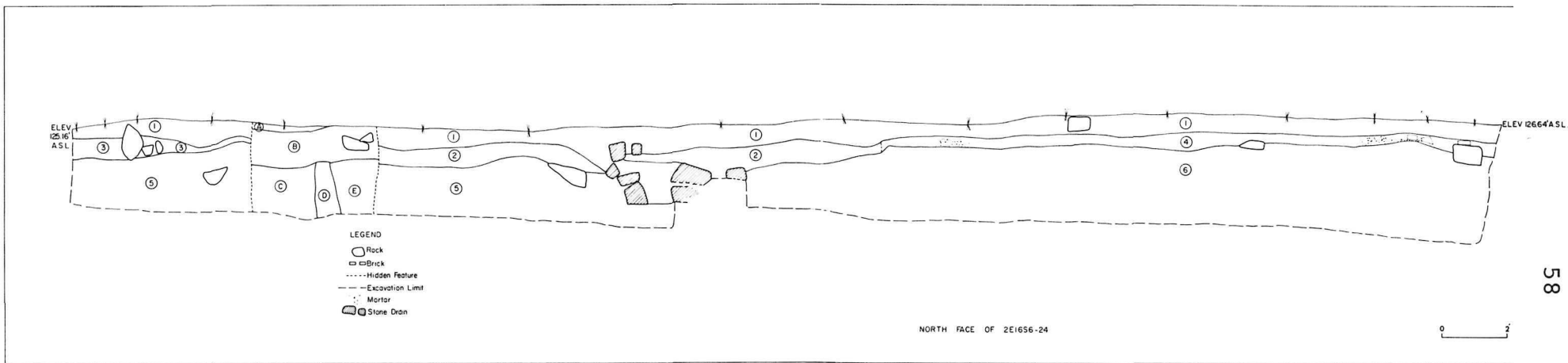

6 The soil layers of the stratigraphic cross-section along the north face of sub-operation 2E16S. 1, 7.5 YR 4/2 dark brown loam, sod layer; 2, 7.5 YR 4/4 dark brown clay with loam and sand, many artifacts; 3, 7.5 YR dark brown loamy clay, small stones and some mortar detritus and charcoal, some artifacts; 4, 10 YR 3/4 dark yellowish brown loam with clay, brick and mortar detritus in varying concentrations with some charcoal and wood fragments; 5, 7.5 YR 4/4 brown sandy clay; 6, 5 YR 4/4 reddish brown sandy clay, some small stones. A, 7.5 YR 4/2 dark brown with intrusions of black, partially formed sod layer. B, 10 YR 3/4 dark yellowish brown, sandy clay, intrusion on 7.5 YR 4/4 brown, mortar detritus, some modern artifacts. C, 10YR 3/4 dark yellowish brown, sandy clay, mortar and brick detritus, stone detritus. D, 7.5 YR 4/4 brown sandy clay. E, 10 YR 3/4 dark yellowish brown, sandy clay with intrusions of black, mortar and brick detritus. (2E-71-102-5)

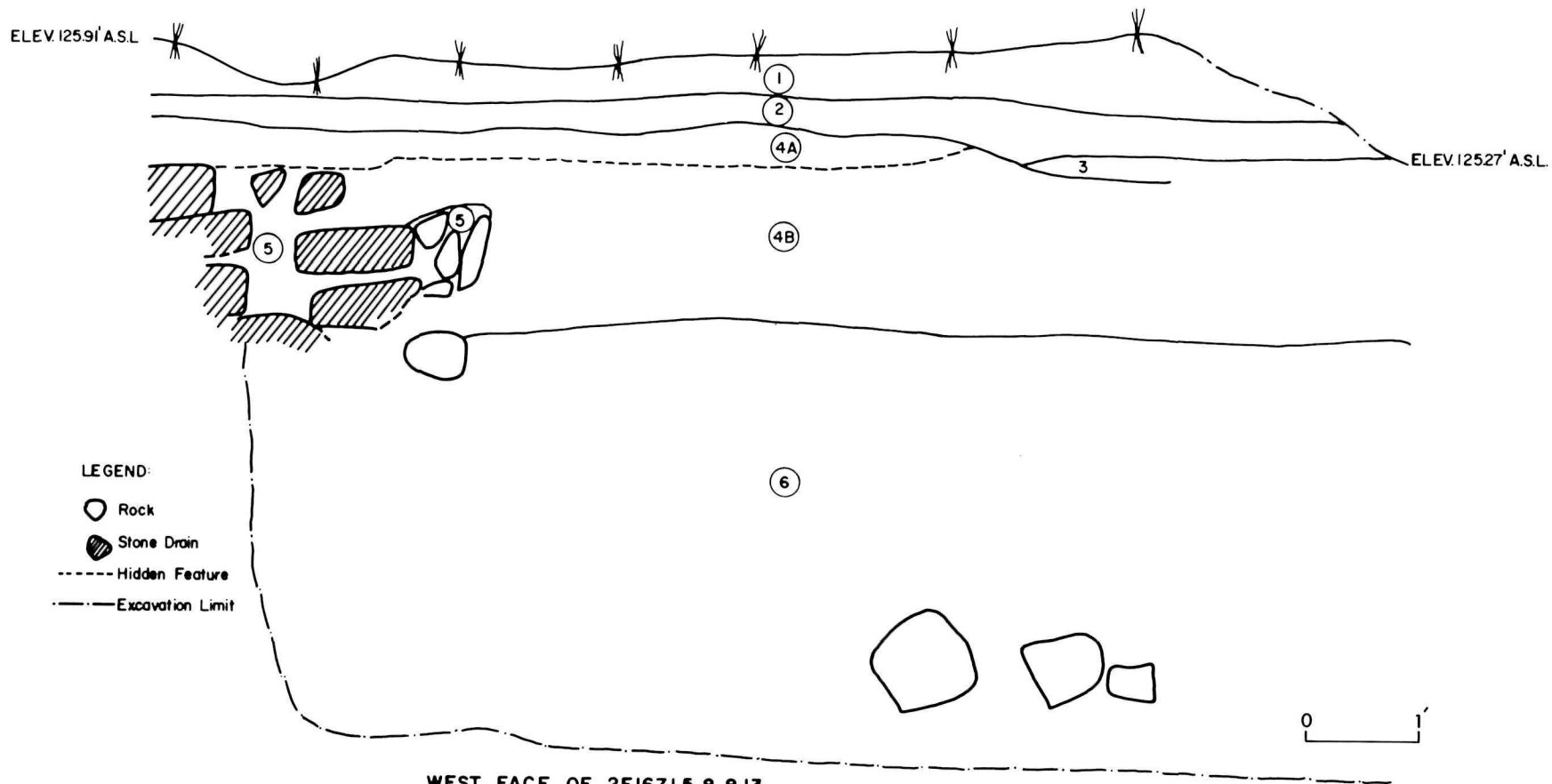

WEST FACE OF 2E16Z1, 5, 8, & 13.

- 7 The soil layers of the stratigraphic cross-section along the west face of lot 2E16Z1, 5, 8, 8₂, 13
 1, 10 YR 3/4 dark yellowish brown loam, sod layer; 2, 10 YR 3/4 dark yellowish brown loamy clay,
 some burnt wood and some artifacts; 3, burnt wood; 4a, 10 YR 4/4 dark yellowish brown sandy
 clay, small pebbles; 4b, 10 YR 3/4 dark yellowish brown, very sandy clay, small stones; 5,
 7.5 YR 4/4 brown, very sandy clay; 6, 7.5 YR 4/4 brown, sandy clay (2E-71-102-3).

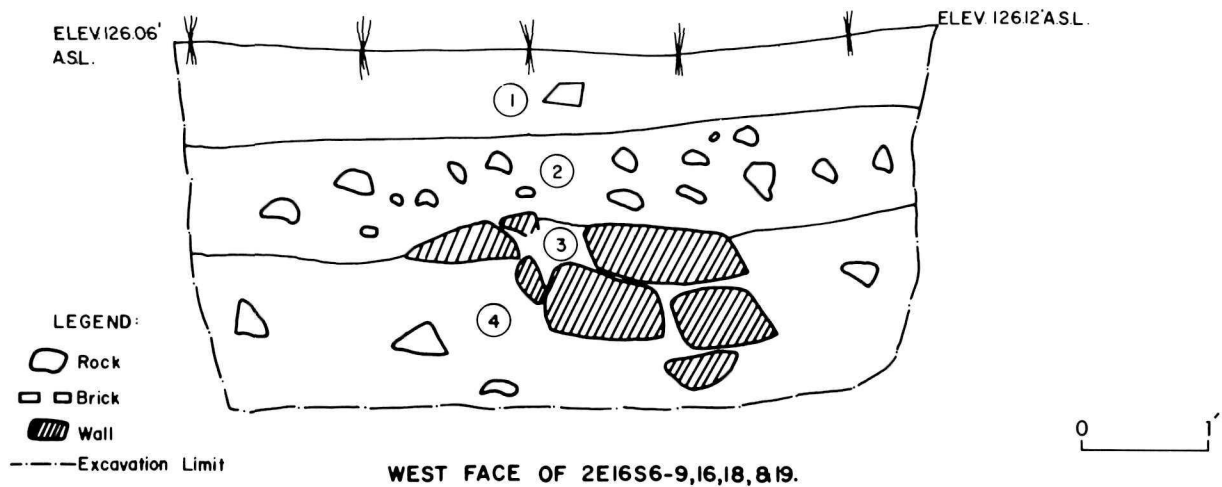

- 8 The soil layers of the stratigraphic cross-section along the west face of lot 2E16S19.
- 1, 7.5 YR 4/2 dark brown loam, sod layer; 2, 7.5 YR 4/4 brown loam with clay, small stones and artifacts, some wood fragments; 3, 7.5 YR 4/4 brown loamy clay with sand, no stones; 4, 7.5 YR 4/4 brown, sandy clay, some stones (2E-71-102-3).



9 Post-excavation shot of 2E16Z5 showing the stone drain, camera facing west, with a two foot scale north-south. (2E-3579 X).



10 Post-excavation shot of the stone drain in 2E16S16 camera facing east, with a two foot scale north-south (2E-3588 X).

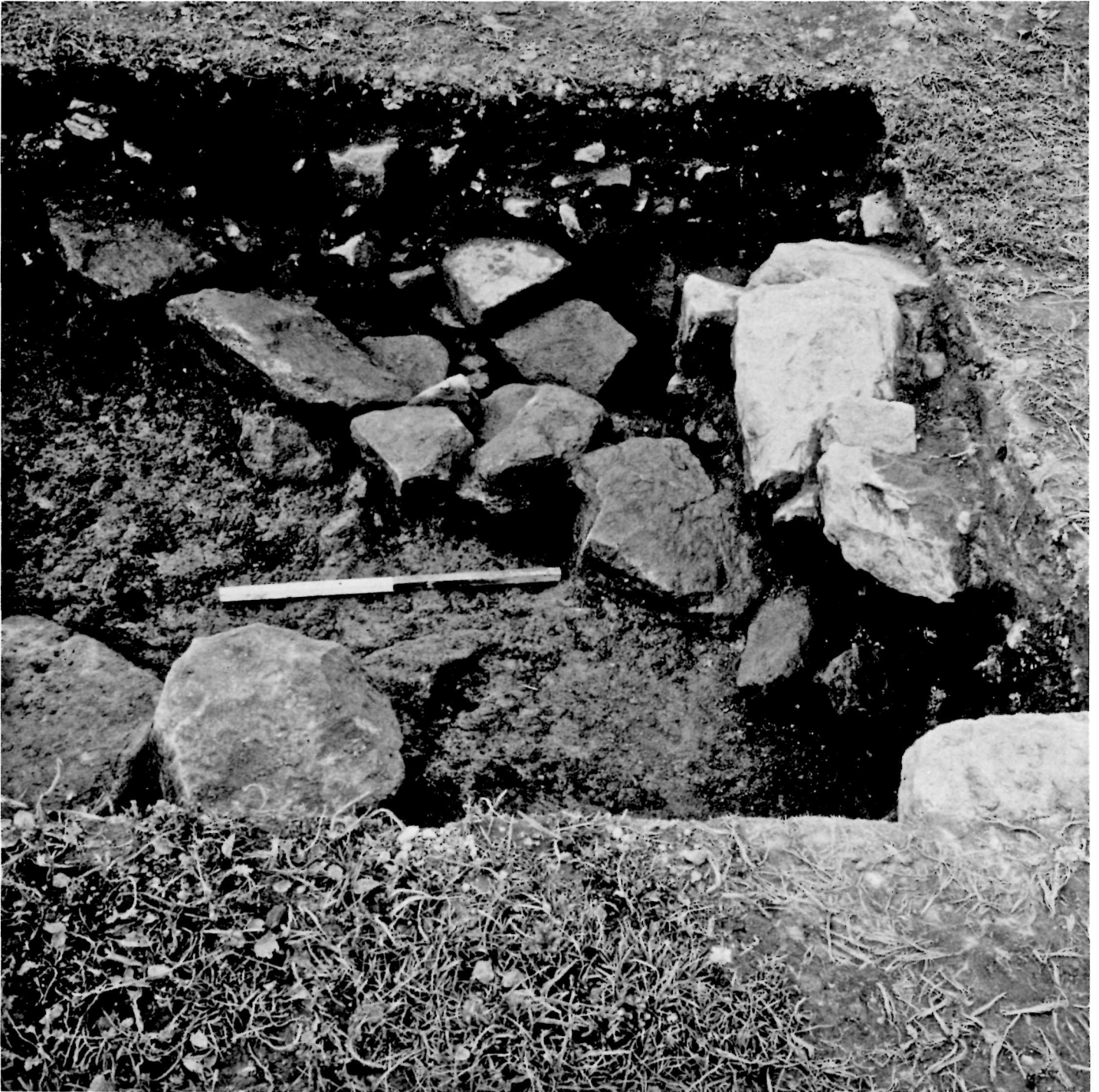

11 Post-excavation shot of the stone drain in 2E16S20, camera facing north-west, with a two foot scale northeast-southwest (2E-3594 X).



12 Post-excavation shot showing the stone drain in 2E16S24, with the camera facing north-west. There is a two foot scale northeast-southwest (2E-3598 X).



13 Post-excavation shot of artifact 2E27A23-1, a wooden post, with camera facing east, and a two foot scale north-south (2E-3519 X).

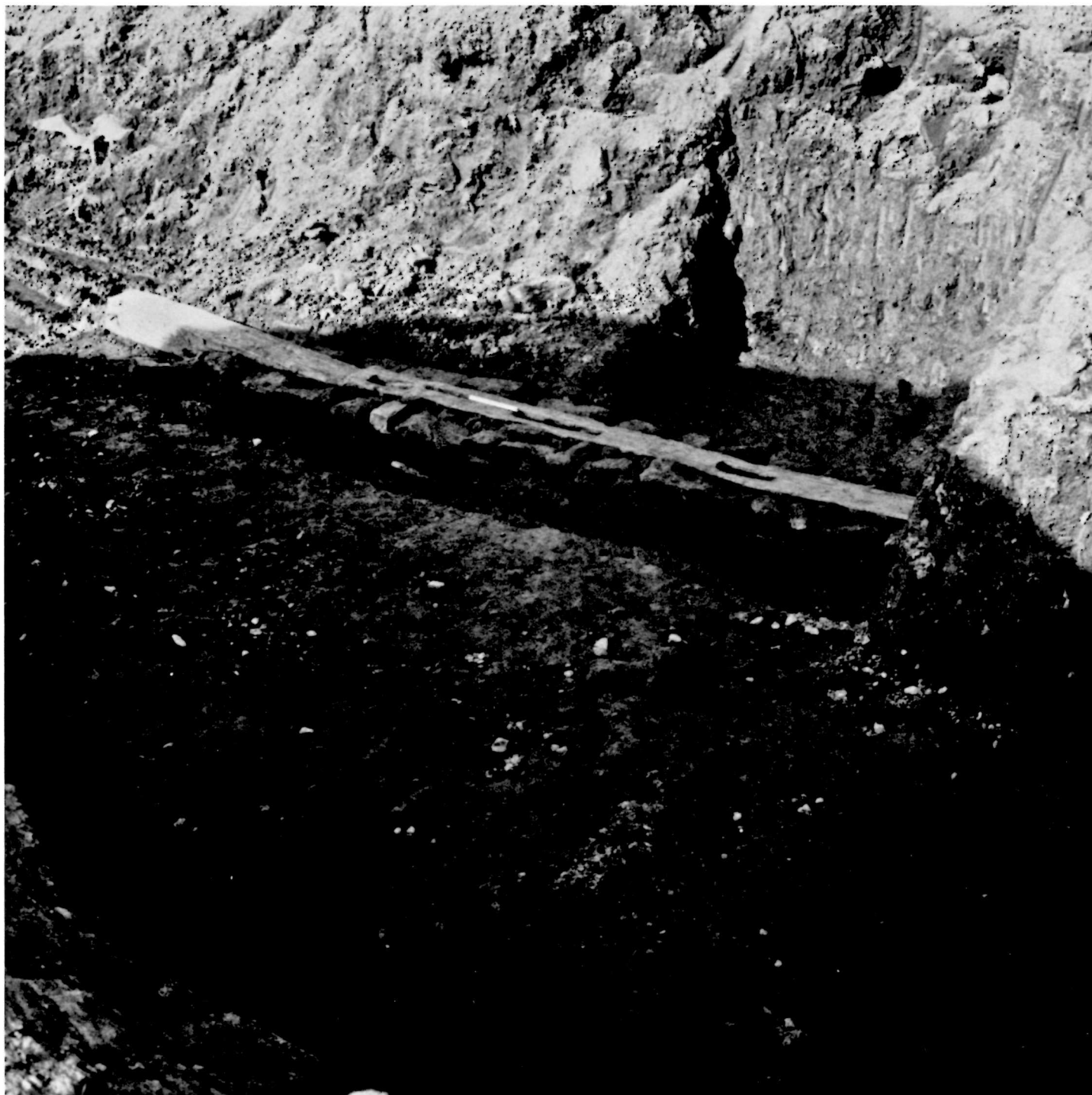





14 Post-excavation view of 2E26X1 showing the two beams and the stone bracing walls. The camera is facing southeast, and there is a two foot scale aligned east-west (2E-3530 X).

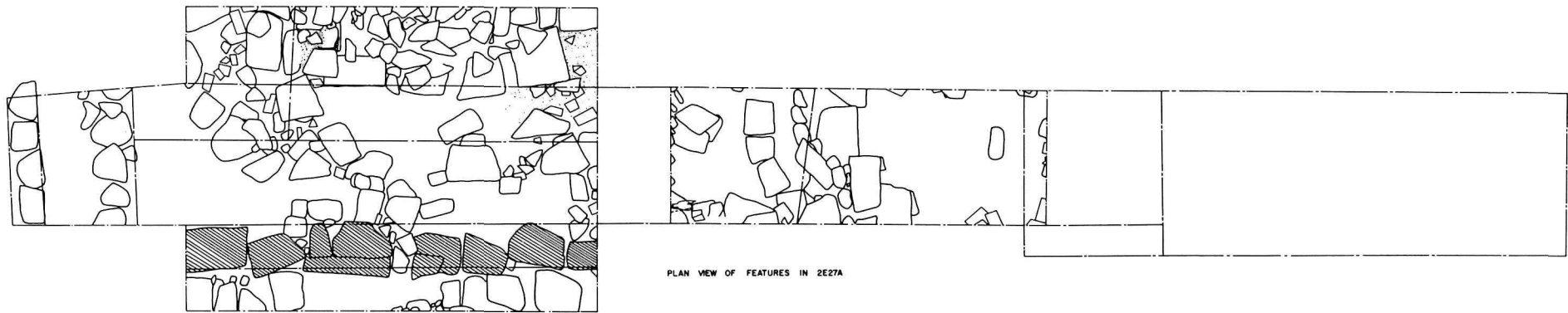

15 Post-excavation view showing the two beams in 2E26X1, camera facing east. There is a two foot scale north-south (2E-3531 X).



16 Plan of the features located in 2E27A (2E-71-102-4).

-  Wall
-  Stone
-  Mortar
-  Excavation Limit
-  Brick

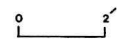

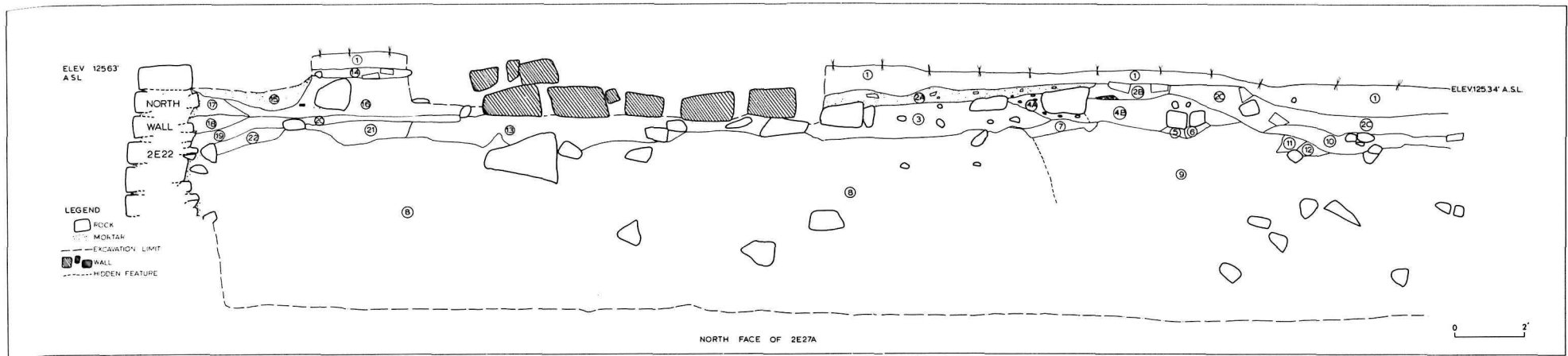

- 17 The soil layers of the stratigraphic cross-section along the north face of suboperation 2E27A.
- 1, 7.5 YR 3/2 dark brown sod layer, loam; 2a, 7.5 YR 3/2 dark brown, loamy clay, dens mortar and brick detritus; 2b, 7.5 YR 4/2 dark brown loamy clay, mortar and brick detritus; 2c, 7.5 YR 4/2 dark brown loamy clay; 3, 7.5 YR 4/4 brown sandy clay; 4a, 7.5 YR dark brown, very sandy clay, small stones; 4b, 7.5 YR 4/4 brown, sandy clay; 5, 5 YR 4/3 reddish brown, sandy clay; 6, 7.5 YR 4/4 brown medium sand; 7, 5 YR 4/3 reddish brown, very sandy clay; 8, 5 YR 4/4 reddish brown clay with some small stones; 9, 5 YR 3/3 dark reddish brown, very sandy clay; 10, 7.5 YR 4/2 dark brown, loamy clay; 11, 7.5 YR 5/6 strong brown, medium to coarse sand with clay; 12, 10 YR 5/8 yellowish brown medium to coarse sand with clay; 13, 7.5 YR 5/6 strong brown, medium sand; 14, 7.5 YR 4/2 dark brown loam with clay, some mortar detritus; 15, 7.5 YR 4/2 dark brown loam, dense whitish mortar detritus; 16, 7.5 YR 4/2 dark brown, sandy and loamy clay; 17, 7.5 YR 4/4 brown, slightly sandy clay; 18, 5 YR 4/3 reddish brown sandy clay; 19, 5 YR 3/4 dark reddish brown sandy clay, some charcoal fragments; 20, 10 YR 3/4 dark yellowish brown loam with clay, wood and charcoal fragments; 21, 7.5 YR 5/4 brown medium sand with clay; 22, 7.5 YR 4/4 brown medium sand with clay (2E-71-102-6).

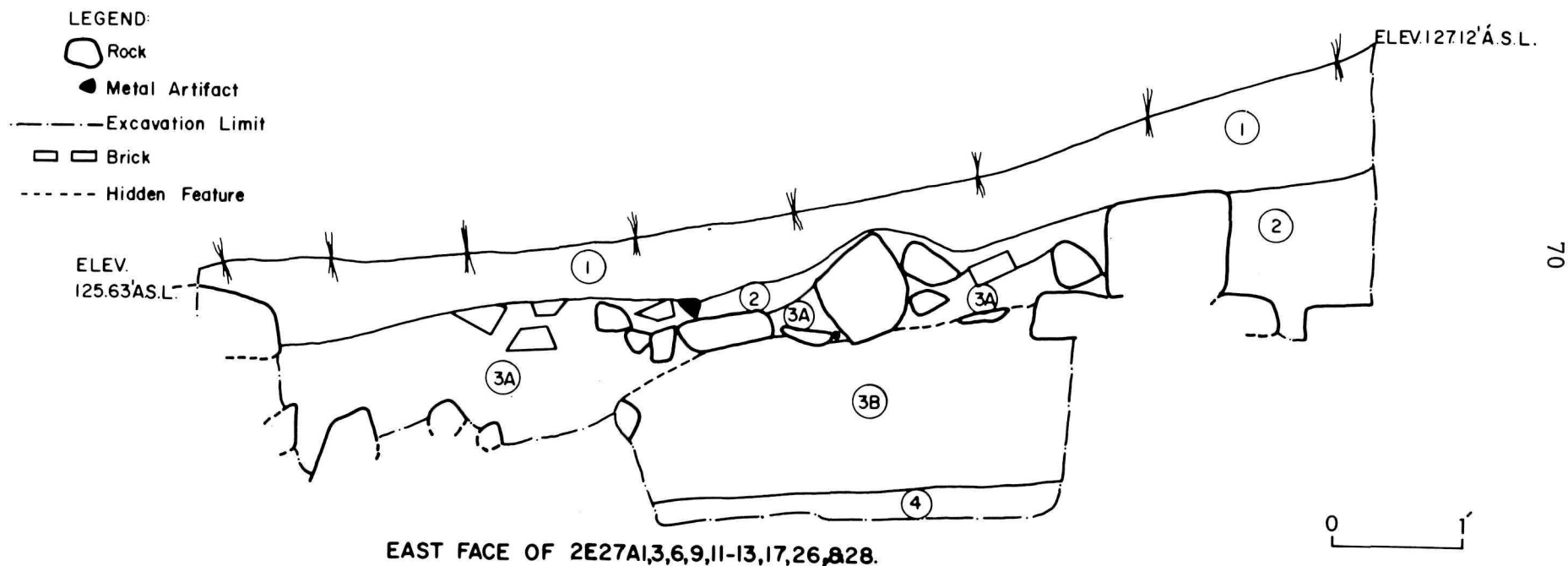

18 The soil layers of the stratigraphic cross-section along the east face of lots 2E27A3, 2E27A9, 2E27A11, 2E27A17, 2E27A26 and 2E27A28. 1, 7.5 YR 3/2 dark brown loam, sod layer; 2, 7.5 YR 4/2 dark brown, sandy and loamy clay; 3a, 7.5 YR 4/4 brown, medium sand with clay; 3b, 7.5 YR 5/4 brown, medium sand with clay; 4, 5YR reddish brown sandy clay with some small stones (2E-71-102-2).

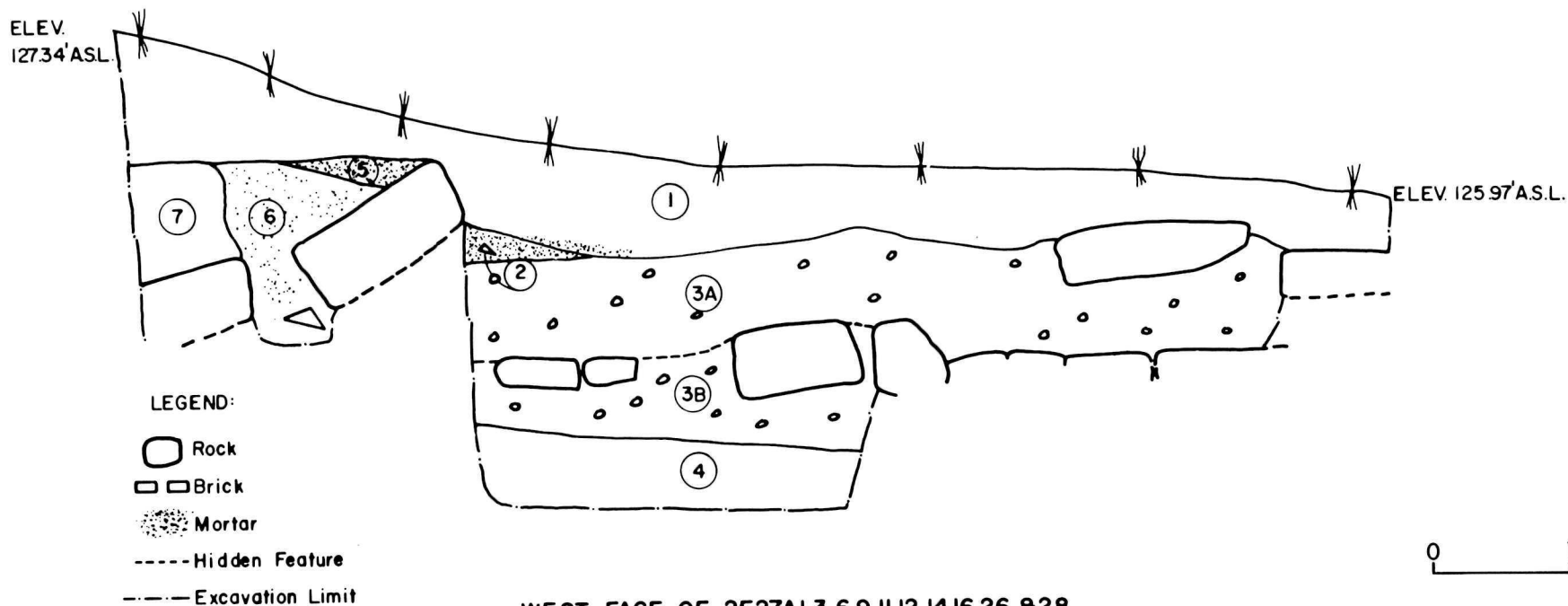

19 The soil layers of the stratigraphic cross-section along the west face of lots 2E27A9, 2E27A11, 2E27A16 and 2E27A28. 1, 7.5 YR 4/2 dark brown loam, sod layer; 2, 10 YR 3/4 dark yellowish brown loam, dense yellow and white mortar detritus with some brick detritus; 3a, 7.5 YR 4/4 brown sandy clay, small pebbles; 3b, 10 YR 3/4 dark yellowish brown sand with clay; 4, 10 YR 4/4 dark yellowish brown medium sand; 5, 10 YR 3/4 dark yellowish brown loam, dense mortar detritus; 6, 10 YR 3/4 dark yellowish brown, dense yellowish mortar detritus with some brick detritus; 7, 10 YR 3/4 dark yellowish brown loam with clay (2E-71-102-2).



20 Post-excavation view showing the wall located in lot 2E27A3, with the camera facing west. There is a two foot scale north-south (2E-3504 X).



21 Post-excavation view showing the wall found in lots 2E27A16 and 2E27A17, camera facing north. There is a two foot scale east-west (2E-3522 X).



22 Post-excavation view showing the wall in 2E27A22, camera facing west with a two foot scale north-south (2E-3509 X).



23 Post-excavation view showing the wall in 2E27A24 with the camera facing east. There is a two foot scale north-south (2E-3609 X).

